

THE EFFECTS OF FEEDING MANAGEMENT AND FEED AREA DESIGN ON DAIRY
CATTLE BEHAVIOR

by

TREVOR JAMES DEVRIES

B.Sc. (Agriculture), The University of British Columbia, 2001

A THESIS SUBMITTED IN PARTIAL FULFILLMENT OF
THE REQUIREMENTS FOR THE DEGREE OF

DOCTOR OF PHILOSOPHY

in

THE FACULTY OF GRADUATE STUDIES

(Animal Science)

THE UNIVERSITY OF BRITISH COLUMBIA

April 2006

© Trevor James DeVries, 2006

ABSTRACT

There has been little in-depth research on measures of feeding behavior in dairy cattle and how management and housing influence these measures. Thus, the first study of this dissertation determined which objective measures of feeding behavior are most repeatable and sensitive to treatment differences. The remaining studies focussed on assessing how management and design of the feeding area affect the behavior of group-housed dairy cows. To determine which management practice has the greatest effect on stimulating cows to feed, two management practices, feed delivery and milking, were separated and changes in feeding behavior were monitored. The results indicated that the daily feeding pattern of group-housed dairy cows is primarily influenced by the timing of feed delivery. A follow-up study investigated the effects of changing the frequency of feed delivery on the behavior of lactating dairy cows. More frequent delivery of feed improved access to feed for all cows, particularly during peak feeding periods, and reduced the degree of feed sorting, which in turn could reduce the between-cow variation in the composition of feed consumed. The last two experiments determined the effects of feed area design on dairy cattle behavior. Changes in behavior were monitored when cows were provided with more feed bunk space than typically provided. Increased bunk space resulted in more space between cows and fewer aggressive interactions while feeding, allowing cows, especially subordinate ones, to increase their feeding activity. The final study of this dissertation determined if the addition of partitions (feed stalls) between adjacent cows would further limit competition at the feed bunk. The addition of feed stalls resulted in a further reduction in aggressive interactions and a further increase in feeding time compared to providing extra bunk space. This research clearly demonstrates that the provision of increased bunk space, particularly when combined with feed stalls, improves access to feed and reduces competition at the feed bunk, particularly for subordinate cows. These findings provide insight into how one can manage and design the feeding environment to increase access to feed, reduce competition at the feed bunk, and reduce the between-cow variation in the composition of feed consumed.

TABLE OF CONTENTS

ABSTRACT	ii
TABLE OF CONTENTS	iii
LIST OF TABLES	v
LIST OF FIGURES	vi
LIST OF ABBREVIATIONS	viii
ACKNOWLEDGEMENTS	ix
CO-AUTHORSHIP STATEMENT	x
CHAPTER 1: General introduction	1
1.1 IMPORTANCE OF FEED INTAKE	1
1.2 MEASURING FEEDING BEHAVIOR	3
1.3 DAIRY CATTLE HOUSING	9
1.4 SOCIAL INFLUENCE ON FEEDING BEHAVIOR	11
1.5 FEEDING MANAGEMENT	13
1.6 FEED AREA DESIGN	16
1.6.1 Feed bunk space	17
1.6.2 Feed barrier design	18
1.7 OBJECTIVES	21
1.8 REFERENCES	25
CHAPTER 2: Measuring the feeding behavior of lactating dairy cows in early to peak lactation	31
2.1 INTRODUCTION	31
2.2 MATERIALS AND METHODS	33
2.3 RESULTS	37
2.4 DISCUSSION	39
2.5 CONCLUSIONS	43
2.6 ACKNOWLEDGEMENTS	44
2.7 REFERENCES	52
CHAPTER 3: Time of feed delivery affects the feeding and lying patterns of dairy cows	54
3.1 INTRODUCTION	54
3.2 MATERIALS AND METHODS	54
3.3 RESULTS	59
3.4 DISCUSSION	60
3.5 CONCLUSIONS	64
3.6 ACKNOWLEDGEMENTS	64
3.7 REFERENCES	69
CHAPTER 4: Frequency of feed delivery affects the behavior of lactating dairy cows	71
4.1 INTRODUCTION	71
4.2 MATERIALS AND METHODS	73
4.3 RESULTS	79
4.4 DISCUSSION	83

4.5 CONCLUSIONS	88
4.6 ACKNOWLEDGEMENTS	89
4.7 REFERENCES	96
CHAPTER 5: Effect of feeding space on the inter-cow distance, aggression, and feeding behavior of free-stall housed lactating dairy cows	99
5.1 INTRODUCTION	99
5.2 MATERIALS AND METHODS	100
5.3 RESULTS	105
5.4 DISCUSSION	107
5.5 CONCLUSIONS	110
5.6 ACKNOWLEDGEMENTS	110
5.7 REFERENCES	116
CHAPTER 6: Feed stalls affect the social and feeding behavior of lactating dairy cows	118
6.1 INTRODUCTION	118
6.2 MATERIALS AND METHODS	120
6.3 RESULTS	125
6.4 DISCUSSION	127
6.5 CONCLUSIONS	133
6.6 ACKNOWLEDGEMENTS	134
6.7 REFERENCES	140
CHAPTER 7: General discussion	142
7.1 MEASURING FEEDING BEHAVIOR	142
7.2 FEEDING PATTERNS	145
7.3 FEEDING MANAGEMENT	146
7.4 FEED AREA DESIGN	151
7.5 CONCLUDING REMARKS	159
7.6 REFERENCES	160
APPENDIX 1: Validation of a system for monitoring feeding behavior of dairy cows	163

LIST OF TABLES

Table 2.1. Regression coefficients for the relationship between time periods for different measures of feeding behavior.	45
Table 2.2. Intercepts and slopes of line equations from the regression of feeding behavior measures in Period 1 versus Period 2.....	46
Table 2.3. Intercepts and slopes of line equations from the regression of feeding behavior measures in Period 2 versus Period 3.....	47
Table 3.1. Total daily feeding time and for the 60-min period following the return from milking for both treatments and for the 60-min period following the delivery of fresh feed for when cows were fed 6 h post-milking.	65
Table 4.1. Ingredient and chemical composition of the total mixed ration.....	90
Table 4.2. Daily feeding time, feeding time during the daytime and early evening hours, during the late evening and early morning hours and during the 90-min period following the delivery of feed for both treatments in Experiment 1 and 2.....	91
Table 4.3. Mean time spent lying per day and the latency to lie after the return from milking for both treatments in Experiment 1 and 2.....	92
Table 5.1. The inter-cow distance (m) with 0.5 m and 1.0 m of allocated feed bunk space/cow with varying numbers of cows present at the feed bunk.....	112
Table 5.2. Measures of feeding behavior with 0.5 m and 1.0 m of allocated feed bunk space/cow.	113
Table 6.1. Incidence of displacements from the feed bunk and the point of initial contact that resulted in a displacement at the feed bunk with 0.64 m of feed bunk space/cow, 0.92 m of feed bunk space/cow, and feed stalls (0.87 m of bunk space/cow with feed stalls).....	135
Table 6.2. Measures of feeding time and inactive standing behavior with 0.64 m of feed bunk space/cow, 0.92 m of feed bunk space/cow, and feed stalls (0.87 m of bunk space/cow with feed stalls).....	136
Table 6.3. Percentage of cows per group at the feed bunk and inactively standing averaged over the period of peak feeding activity (90 min following the delivery of fresh feed) with 0.64 m of feed bunk space/cow, 0.92 m of feed bunk space/cow, and feed stalls (0.87 m of bunk space/cow with feed stalls).....	137

LIST OF FIGURES

Figure 1.1. (a) Log-survivorship and (b) log-frequency curves showing the fast process (line with small dashes), slow process (line with large dashes), and the combined curve.....	22
Figure 1.2. (a) The frequency distribution of the log-transformed intervals between feeding bouts. (b) The frequency distribution of the log-transformed intervals fitted with a mixture of two normal distributions, effectively separating the within meal intervals and the between meal intervals.....	23
Figure 1.3. Front view and cross-sectional view of a portion of a headlock (a) and a post-and-rail (b) feed barrier.....	24
Figure 2.1. The relationship of (a) total daily meal time (min/d) and (b) meal frequency (meals/d) calculated with a pooled meal criterion (27.7 min) and with individual meal criterion.....	48
Figure 2.2. Square root transformed relative frequency distribution of the intervals (n = 180,676) between the electronic feed bunk monitoring system data points fitted with a mixed distribution model.....	49
Figure 2.3. The relationship between the average feeding activity (hits/d) of 21 cows for (a) Period 1 and 2 and (b) Period 2 and 3.....	50
Figure 2.4. The relationship between the average total daily meal time (min/d) of 21 cows for (a) Period 1 and 2 and (b) Period 2 and 3.....	51
Figure 3.1. Percentage of cows per group present at the feed bunk over a 24-h period (percentage for each 60-s interval during the day) for two treatments: 1) cows were milked and fed at 0530 and 1730 h, and 2) cows were milked at 0530 and 1730 h and fed at 1130 h and 2130 h.....	66
Figure 3.2. The relationship of feeding time (min) during the 60-min period following (a) the return from milking and (b) the delivery of fresh feed measured on dairy cows provided with either fresh feed upon return from milking or fresh feed 6 h after milking.....	67
Figure 3.3. Percentage of cows per group lying over a 24-h period (percentage for each 10-min interval during the day) for two treatments: 1) cows were milked and fed at 0530 and 1730 h, and 2) cows were milked at 0530 and 1730 h and fed at 1130 and 2130 h.....	68
Figure 4.1. Percentage of cows per group present at the feed bunk over a 24-h period (percentage for each 10-min interval during the day) in (a) Experiment 1 for 2 treatments: 1) cows fed at 0530 h, and 2) cows fed at 0530 and 1515 h; and (b) Experiment 2 for 2 treatments: 1) cows fed at 0530 and 1515h, and 2) cows fed at 0530, 1100, 1515, and 2230 h.....	93
Figure 4.2. Percentage of cows per group lying down over a 24-h period (percentage for each 10-min interval during the day) in (a) Experiment 1 for 2 treatments: 1) cows fed at 0530 h, and 2) cows fed at 0530 and 1515 h; and (b) Experiment 2 for 2 treatments: 1) cows fed at 0530 and 1515h, and 2) cows fed at 0530, 1100, 1515, and 2230 h.....	94
Figure 4.3. Percentage NDF (DM basis) of the TMR in the feed bunk over the course of the day for: a) 2 treatments: 1) cows fed at 0530 h, and 2) cows fed at 0530 and 1515 h, and b) 2 treatments: 1) cows fed at 0530 and 1515 h, and 2) cows fed at 0530, 1100, 1515, and 2230 h.....	95
Figure 5.1. Number of cows per group present at the feed bunk over a 24-h period (number for each 60-s interval during the day) for both 0.5 m and 1.0 m feed bunk space/cow treatments.....	114

Figure 5.2. The relationship of post-feeding (PF) feeding activity (hits per 90-min PF period) measured on dairy cows with 0.5 m of feed bunk space/cow and with 1.0 m of feed bunk space/cow.....115

Figure 6.1. Diagrams of the (A) side and (B) rear-diagonal views of the feed stalls used in this study, showing the dimensions and placement of the feed stalls, respectively.....138

Figure 6.2. Percentage of cows per group present at the feed bunk over a 24-h period (percentage for each 60-s interval during the day) for 3 treatments: 1) 0.64 m of feed bunk space/cow, 2) 0.92 m of feed bunk space/cow, and 3) feed stalls (0.87 m of bunk space/cow with feed stall partitions).....139

LIST OF ABBREVIATIONS

ADF	Acid detergent fiber
CP	Crude protein
DIM	Days in milk
DM	Dry matter
DMI	Dry matter intake
N	Nitrogen
NDF	Neutral detergent fiber
OM	Organic matter
PF	Post feeding
SD	Standard deviation
SE	Standard error
TMR	Total mixed ration
1x	Once per day
2x	Twice per day
4x	Four times per day

ACKNOWLEDGEMENTS

First and foremost, I would like to thank my supervisor Marina (Nina) von Keyserlingk for her continual encouragement, guidance and support throughout my graduate studies. She gave me the freedom to take my research in a direction that I wanted and the support that I needed to carry it out. This allowed us to develop a strong and successful research program together, which was extremely exciting and mutually beneficial. I would also like to thank Nina for opening up many other doors for me by allowing me to engage in research projects outside my thesis, assist her in teaching, supervise students, and help write research grants. I would also like to especially thank Dan Weary for his guidance during my research, his many ideas, his careful editing of my writing, and his statistical analysis support. I am particularly grateful for Dan's continual barrage of challenging questions, through which he instilled and cultured my critical thinking skills.

I would also like to thank the other members of my supervisory committee. The guidance and support I've received from Karen Beauchemin from afar throughout my research program has been greatly appreciated. Also, I have many thanks to offer to Jim Thompson, particularly for his thoughtful comments and attention to detail in his editing of this thesis. I would like to thank my supervisory committee on a whole for the opportunity to switch in the Ph.D. program and engage myself in such an exciting research area. I am also appreciative for the opportunity they provided in my research visit to the Czech Republic, which was an unimaginable learning experience. Finally, I would also like to express my gratitude to the late Dr. Jim Shelford for inspiring me as an animal science undergraduate student and for acting as my supervisor in the early stages of my studies.

I would also like to thank David Fraser and the rest of the Animal Welfare Program for all the interesting discussions, ideas, and support. They created and continue to create an excellent working environment and a place that I enjoyed coming to each day. Specifically I'd like to thank two of my cow research colleagues, Frances Flower and Julie Huzzey, who have provided much help and support. In the acknowledgement sections at the end of each experimental chapter in this dissertation I have thanked the various people who made contributions to each specific project. I will not mention all their names again, however, I am very thankful for the help provided by these people.

I would also like to thank to the UBC Faculty of Land and Food Systems (*nee* Agricultural Sciences) for the Elizabeth R. Howland Fellowship and to the Natural Sciences and Engineering Research Council of Canada (NSERC) for the NSERC Post Graduate Scholarship and NSERC Canada Graduate Scholarship.

Finally, I would like to thank my family for all their support during these many years I have been at UBC. Specifically, I thank my parents for continually encouraging me to pursue my studies and my wife, Linda, for her endless support, particularly in the past year and a half.

CO-AUTHORSHIP STATEMENT

Chapter 2:

I was responsible for the experimental design, data collection, all statistical analyses, and writing the manuscript.

Marina von Keyserlingk, Dan Weary, and Karen Beauchemin contributed to the experimental design, the choice of statistical tests and to the interpretation and presentation of the manuscript.

Chapter 3:

I was responsible for the experimental design, data collection, all statistical analyses, and writing the manuscript.

Marina von Keyserlingk contributed to the experimental design and to the interpretation and presentation of the manuscript.

Chapter 4:

I was responsible for the experimental design, data collection, all statistical analyses, and writing the manuscript.

Marina von Keyserlingk and Karen Beauchemin contributed to the experimental design, the choice of statistical tests and to the interpretation and presentation of the manuscript.

Chapter 5:

I was responsible for the experimental design, data collection, all statistical analyses, and writing the manuscript.

Marina von Keyserlingk and Dan Weary contributed to the experimental design, the choice of statistical tests and to the interpretation and presentation of the manuscript.

Chapter 6:

I was responsible for the experimental design, data collection, all statistical analyses, and writing the manuscript.

Marina von Keyserlingk contributed to the experimental design, the choice of statistical tests and to the interpretation and presentation of the manuscript.

Appendix 1

I was responsible for the experimental design, data collection, all statistical analyses, and writing the manuscript.

Marina von Keyserlingk, Dan Weary, and Karen Beauchemin contributed to the experimental design, the choice of statistical tests and to the interpretation and presentation of the manuscript.

CHAPTER 1: General introduction

1.1 IMPORTANCE OF FEED INTAKE

One of the most important challenges that any animal faces to ensure its every day survival is obtaining a supply of food (Sitter, 1999). The consumption of food is a complex activity that consists of a series of actions or behaviors. Initially, the animal must search for food, and then be able to recognize a potential food source and move towards it. Once the animal has approached the food source, it must undertake a sensory appraisal of the food. Finally, it must initiate the behaviors associated with prehension and ingestion (McDonald et al., 2002). Feeding behavior and digestive tract physiology in animals are closely related. Ruminants are herbivores whose digestive tract is highly developed to include a unique mode of digestion that allows them to efficiently access energy from fibrous feeds compared to other herbivores. This digestive system enables them to consume large quantities of cellulose and other plant polysaccharides and is characterized by pre-gastric retention and fermentation by symbiotic microbes (Van Soest, 1994; Cheeke, 1999). There are many species of ruminants, including traditional wild species such as deer, elk, and moose, and many domesticated species including sheep, goats, and cattle (Van Soest, 1994).

The unique digestive system of cattle allows them to efficiently utilize feeds that humans are unable to utilize, and in turn produce products, such as milk and meat, that humans are able to consume (Van Soest, 1994). Over the years, humans have taken advantage of this and have utilized cattle to produce much of their food. The feeding management of domesticated cattle assumes that when there are increased opportunities to feed, the animal will increase its daily production (McDonald et al., 2002), and thereby increase the food supply to humans. Thus, many cattle are fed *ad libitum*, that is, given unlimited opportunity to consume feed (Forbes, 2000).

This management practice is used both when feeding cattle that are housed intensively (e.g. lactating cows housed in a free-stall barn or beef cattle housed in a feedlot), or those housed extensively on pasture. Despite this freedom of access to food, there are situations in which animals over or under eat (Forbes, 1995). Underfeeding restricts production and can negatively affect health. Overfeeding can increase feed costs, result in excess excretion of nutrients, and may also have adverse health affects (NRC, 2001).

Genetic selection practices have given rise to modern-day dairy cattle that are capable of producing quantities of milk in excess of what can be maintained by nutrient intake, particularly soon after calving. Parturition signals the onset of lactation, a time of high nutrient demand. However, the periparturient period corresponds to a time when most dairy cattle are unable to eat sufficient amounts of feed to meet this increase in nutrient demand. The dairy cow is able to compensate for this short-term fall in nutrient intake by metabolizing body tissues. However, this also increases the risk of the animal succumbing to disease (Phillips, 2002).

The failure to obtain sufficient nutrients during this time of the production cycle indicates that there are factors regulating the feeding behavior of these animals. Even though lactating dairy cattle may be given unlimited access to feed there are several factors, both physiological and external, that may affect the decision of whether cows will initiate or terminate a feeding event. The control mechanisms governing feed intake in farm animals can be divided into three levels. At the level of the digestive system, the quantities of digesta (e.g. gut fill) may determine whether or not an animal can ingest more feed. At the metabolic level, concentrations of nutrients, metabolites, and hormones may stimulate the nervous system to start or stop feeding. Finally, there are external influences, such as management and housing variables that will also influence food intake (McDonald et al., 2002). It is necessary to understand how each of these

three levels affects feeding behavior in dairy cattle. This information will improve our ability to design rations as well as housing and management systems that are conducive to maintaining optimum feeding behavior and, in turn, nutrient intake, which is essential for maximizing lactation, prevention of disease, and cattle well-being.

To date, many researchers have evaluated the internal factors (metabolic and nutritional) that contribute to the physiological regulation of feeding behavior (see reviews by Allen, 2000; Ingvarlsen and Andersen, 2000) The identification of these physiological factors is necessary for the formulation of rations that help maximize feed intake, particularly for those early lactation cows whose energy demands often cannot be met (Ingvarlsen and Andersen, 2000). In the past, however, far fewer researchers have evaluated the external influences (e.g. housing and management) on feeding behavior. Therefore, this introduction provides a review of the scientific literature on the feeding behavior of dairy cows, with a particular emphasis on how external factors regulate feeding behavior. Additionally, to understand how feeding behavior is affected by various regulatory mechanisms, one must be able to quantify this behavior. Therefore, a summary of the methodologies available for measuring the feeding behavior of dairy cattle is also provided.

1.2 MEASURING FEEDING BEHAVIOR

The feeding behavior of most animals can be recorded as events that include bites or visits to a feeder (Mayes and Duncan, 1986; Nielsen, 1999). Visits to a feed source or feeder are usually interspaced by numerous short intervals that in turn are interspaced by long intervals. Langton et al. (1995) gives the example of a bird pecking with many short intervals between pecking events. These short intervals are followed by a longer non-feeding interval indicating

cessation of the previous bout or meal (Mayes and Duncan, 1986), prior to the initiation of a new bout of pecks or the next meal. Researchers have suggested that the meal, rather than an individual feeding event, is a more biologically relevant unit describing animal feeding behavior (Sibly et al., 1990; Tolkamp et al., 2000). Therefore, the challenge is to objectively separate feeding events into meals.

Identifying which intervals are between meals, versus shorter gaps within a meal, can be problematic. The difference between intervals within meals compared to those between meals has been called the ‘meal criterion’. The meal criterion has been defined as the longest non-feeding interval that is still considered an interval within a meal (Tolkamp and Kyriazakis, 1999a; Yeates et al., 2001). Unfortunately many researchers have determined the meal criterion using arbitrary methods (e.g. Wangsness et al., 1976; Sowell et al., 1999; Gibb et al., 1998) making it difficult to assess the validity of their results. If the meal criterion is calculated quantitatively, categorizing feeding events into meals is more easily repeatable (Slater and Lester, 1982; Berdoy, 1993). A standard quantitative technique of grouping events into meals allows for comparison of feeding patterns both within and between experiments (Yeates et al., 2001).

Two methods traditionally used to quantitatively calculate meal criteria are the log-survivorship analysis (e.g. Slater and Lester, 1982) and the log-frequency analysis (e.g. Sibly et al., 1990; Langton et al., 1995). These methods both fit a ‘broken-stick’ model to the log-transformed frequency (cumulative frequency for the log-survivorship analysis – where cumulation starts with the longest interval) distribution of the intervals between behavioral events (see Figure 1.1) (Tolkamp and Kyriazakis, 1999a). In both cases the issue of splitting behavior into bouts is generally regarded as a problem that can be solved quantitatively by

considering behavioral events as occurring according to Poisson processes, that is, purely at random. Moreover, these models assume the probability of initiating an event is independent of the time since the last event of the same type (Tolkamp et al., 1998). The frequency distribution of the intervals between such events can be described with a negative-exponential equation (Slater and Lester, 1982; Sibly et al., 1990; Langton et al., 1995).

The frequency distribution of between-feeding intervals for many species cannot be described with just one negative exponential. Intervals between feeding events are often analyzed using at least two processes (e.g. Mayes and Duncan, 1986; Sibly et al., 1990; Berdoy, 1993; Langton et al., 1995). Two frequency distributions are considered to be the result of a fast process, resulting in intervals within bouts, and a slower process, resulting in intervals between bouts (Slater and Lester, 1982; Sibly et al., 1990; Langton et al., 1995). These distributions, whose frequencies are log-transformed before modeling, are then described with negative exponentials. The parameters obtained, after fitting either the log-survivorship (Figure 1.1a) or the log-frequency (Figure 1.1b) curves with negative exponential distributions, are used to estimate a separation point between the two distributions, which is the meal criterion (Slater and Lester, 1982).

Survivorship curves show the cumulative frequency of intervals with a length $> t$ on the Y-axis against interval length, t , on the X-axis (Tolkamp et al., 1998). Several methods have been used to estimate a meal criterion from this log-survivorship curve, including visual assessment. However, the subjective manner of this technique is cause for concern. For example, Metz (1975) visually examined log-survivorship curves and concluded that 20 min was an appropriate criterion for cows, while Dado and Allen (1993), using the same method, concluded that a 7.5 min criterion was appropriate. The limitations of this technique resulted in a move

towards more objective methods to calculate meal criteria from these curves (Slater and Lester, 1982).

Regardless of this, there is a major flaw in the use of log-survivorship analysis for the determination of a meal criterion. Sibly et al. (1990) raised objections over the use of this methodology on the basis that cumulative frequencies are not independent and, thus, are not suitable for statistical analysis (Tolkamp et al., 1998). For this reason, Sibly et al. (1990) and Langton et al. (1995) proposed the use of log-frequency distributions that also assumed the meal criterion to occur at the intersection point between the two negative exponential curves, but avoided the complication of using dependent observations.

This refined log-frequency analysis (Sibly et al., 1990; Langton et al. 1995) is suitable for analyzing bouts of behavior where the probabilities of both the start of an event within a bout as well as the bouts themselves are independent of the last event or bout (Tolkamp et al., 1998). However, this technique fails to take into consideration satiety (Tolkamp et al., 1998; Tolkamp and Kyriazakis, 1999a; Yeates et al., 2001). The satiety concept predicts that the probability of an animal initiating a meal increases with time since the last meal (Metz, 1975; Simpson and Ludlow, 1986). As the duration of non-feeding increases, hunger motivation will increase the likelihood of the start of a new meal (Simpson and Ludlow, 1986). This would translate into few short and few long intervals between meals (Tolkamp and Kyriazakis, 1999a). This contradicts the assumption that the probability of an animal initiating an event is independent of the last time since the last event. In the negative-exponential distribution, the model predicts that the frequency is highest for the shortest interval length, and decreases exponentially with increasing interval length (Tolkamp et al., 1998).

Another criticism of negative exponential modeling is that it conflicts with the idea that the behavior of animals in intervals within meals differs from that in intervals between meals (Tolkamp et al., 1998). For example, Simpson (1990) showed that locusts typically perch a certain distance away from the food source between meals but remain near the food source and do not perch during intervals within a meal. Similarly, cows often ruminate and rest between meals, but fail to undertake these behaviors during intervals within a meal (Metz, 1975). Moreover, during very short intervals it is physically impossible to engage in typical between meal behaviors (e.g. lying). Thus, it is difficult to believe that very short intervals could be intervals between meals as the negative-exponential models would predict (Tolkamp et al., 1998).

Taking into consideration the shortfalls of both the log-frequency and the log-survivorship analyses Tolkamp et al. (1998), Tolkamp and Kyriazakis (1999a), and Yeates et al. (2001) proposed a method that objectively defined a biologically meaningful meal criterion. Based on the satiety concept, they argued that the probability of an animal initiating a meal was not likely to be constant; rather it would increase with increasing time since the last meal. Their proposed model allows for a low frequency of short intervals between meals (Tolkamp et al., 1998; Tolkamp and Kyriazakis, 1999b).

Tolkamp et al. (1998) noticed that the frequency distribution of intervals was extremely skewed. These researchers then log-transformed the intervals between feeding events to normalize the data (see Figure 1.2a). The frequency distribution of the log-transformed intervals showed two normal distributions: one distribution of within meal intervals and a second representing between meal intervals (see Figure 1.2b) (Tolkamp et al., 1998). These researchers then applied a double Gaussian model, fitting a mixture of two normal distributions to the log-

transformed intervals. The curves of the distribution were modeled and maximum likelihood estimates of the parameters were obtained (Figure 1.2b). The meal criterion was calculated to be the point where the minimum numbers of intervals were mis-assigned, that is, where the two log-normals cross (Tolkamp et al., 1998).

The concept of a log-normal distribution is not unique in biological systems (Tolkamp et al., 1998). For example, the intervals between vocalizations in turkeys (Schleidt, 1965) and the intervals within bouts of pecking by chicks (Machlis, 1977) can both be described using a log-normal distribution. However, Tolkamp et al. (1998) appears to be the first to propose a biological mechanism (e.g. satiety) to account for the log-normal distributions of intervals between meals.

The research by Tolkamp and colleagues (Tolkamp et al., 1998; Tolkamp and Kyriazakis, 1999a; Yeates et al., 2001) was based on the behavior of group-housed cows that were restricted to eating from feeding stations and thus, may not account for all of the competitive interactions that occur during feeding in commercial loose-housed systems. Further research is needed to assess whether this method of determining meal criteria can be applied to data obtained from group-housed animals fed in more competitive, commercial type environments.

The measurements used to describe feeding behavior are those describing the time course of food intake (Nielsen, 1999). The measurements that are typically used include meal size, frequency, and duration (Senn et al., 1995; Nielsen, 1999). These measurements all require a meal criterion to discriminate between meals. Meal frequency (meals/d) is calculated by counting the number of intervals per day that exceed the length of the meal criterion and adding one. Meal duration (min/meal) is calculated as the time from the beginning of the first feeding event until, but not including, an interval between events that exceeds the meal criterion. Meal size (kg/meal)

is the total amount of feed ingested during each meal. Authors have argued that cow feeding events are clustered in meals (Tolkamp and Kyriazakis, 1999a), which can be biologically identified (Tolkamp et al., 2000), and therefore should be used in the analysis of feeding behavior. Unfortunately, there has been no research on the within cow repeatability of various measures of feeding behavior. This is important since measures of feeding behavior that are highly repeatable will be most sensitive for detecting treatment differences. Further, future research will be limited if it is based on measures that are only weakly repeatable.

1.3 DAIRY CATTLE HOUSING

Modern-day dairy cattle (*Bos taurus*) were likely domesticated (circa 6200 BC) from the now extinct wild ox, or aurochs (*Bos primigenius*) (Clutton-Brock, 1999). Since that time they have been traditionally housed on pasture and met their nutritional needs by grazing and browsing. With the intensification of the dairy industry and the increased productive capabilities of dairy cattle, there has been a move to exclusively house dairy cattle indoors and feed them conserved feeds. Phillips (2001) suggests that housing of cattle has become an economic necessity in many parts of the world, particularly North America and Europe. Increases in populations of both man and domestic animals have increased the pressure for the best land to be used for cropping rather than grazing. In many countries, cows are housed indoors for at least part of the year because grass and other crops for grazing will only grow during certain times of the year. Housing cattle also increases the opportunity to mechanize milking and other aspects of routine animal care. Further, and probably most importantly, housing dairy cattle allows for more control of their diet (Phillips, 2001). To maintain the high level of production that modern-day dairy cows are capable of, they must consume a nutrient dense diet (consisting of conserved feed

sources) to meet their requirements. In North America and in parts of Europe, where the grazing season is short, the indoor housing of dairy cattle is the most efficient way to provide this type of diet throughout the day.

There are two common systems for housing dairy cattle indoors: 1) individual confinement in tie stalls and, 2) group housing. In the tie stalls, cows are tethered in an individual stall, where they lie, stand, receive food and water, and are often milked. In the group-housed system, cows are permitted free movement at all times except during milking when they are confined in the parlor. In this latter system, cows eat, drink, stand, and lie down in common areas. In group-housed systems, such as dry lot dairies, the lying area may consist of an open area containing a bedding pack where animals can lie anywhere they want. In an effort to conserve space, reduce labor, and reduce the impact of environmental factors on the cows (e.g. moisture) many modern group-housed systems now make use of individual lying cubicles (free stalls) for the animals to lie down in.

Traditionally in North America, most dairy operations have employed the use of tie-stall housing systems. In the past few decades this trend has been changing. Recent surveys in the United States indicate the number of operations using free stalls rose from 24.4% of all operations in 1995 to 30.8% in 2001 (USDA, 1996; 2002). Concurrently, the number of operations using tie stalls declined from 61.4 in 1995 to 52.5% in 2001 (USDA, 1996; 2002).

Despite the move towards group-housed facilities, much of the research to-date on dairy cattle feeding behavior has been completed with individually housed animals. This may be due to the ease with which accurate data can be obtained (i.e. individual feed intake, feeding time) for tie-stalled cows. Over the years, several researchers (e.g. Heizer et al, 1953, Harb et al., 1985; Empel et al., 1993; Haley et al., 2000) have compared tie-stall to group-housing systems,

focusing primarily on differences in feed intake and milk production. Unfortunately, the findings of these studies are quite variable, most likely as result of methodological differences and weaknesses (i.e. few animal numbers, lack of treatment replicates).

1.4 SOCIAL INFLUENCE ON FEEDING BEHAVIOR

Despite no clear answer as to whether or not feeding behavior differs between tie-stall and loose housing, there is a distinct difference between the two systems that could influence their behavior. In loose-housing systems animals have the opportunity to exercise and perform normal social behavior (Boe and Faerevik, 2003). It is believed that social behavior in group-housed systems can play a major role in the modulation of feeding activity (Grant and Albright, 2000). Specifically, both behavioral synchronization and competitive behavior have the potential to influence the feeding behavior of lactating dairy cows.

Under traditional extensive grazing systems, cattle will often synchronize their behavior; that is, many animals in the group will feed, ruminate, and rest at the same times (Miller and Wood-Gush, 1991; Rook and Huckle, 1995). On modern dairy operations, cows also synchronize their behavior, particularly when feeding. Curtis and Houpt (1983) describe that when cows are fed in groups the initiation to feed by one animal will often stimulate the other animals regardless of whether they show signs of hunger. Despite this, researchers have indicated that the synchronization of behaviors may be reduced when cattle are group-housed indoors. O'Connell et al. (1989) compared the behavioral patterns of dairy cows on pasture and during confinement in a loose-housing type system. They noted that the majority of grazing in pasture occurred in the 3 h immediately after the cows returned from milking, with approximately 90% of the animals feeding. When fed indoors, animals responded to the delivery of fresh feed, however, less than

40% of the animals were observed to feed at this peak time. Miller and Wood-Gush (1991) performed a similar experiment to O'Connell et al. (1989), noting a high degree of synchrony in the outdoor-housed cattle, with approximately 90% of the cows feeding together at certain times. In contrast, this synchrony was reduced when the animals were housed indoors, with only a maximum of 60% of the cows feeding at a given time. Even though the loss of synchronization indoors is a widely accepted concept, few researchers have tested why this occurs. Miller and Wood-Gush (1991) suggested that synchrony between animals may break down in housed cattle in which competition for resources may lead to animals feeding and resting at different times to avoid excessive aggression. Based on this, it could be hypothesized that those management and housing aspects that reduce competition have the potential to allow for more synchronized behavior. Unfortunately, there has been little research to verify this.

Cattle are gregarious animals that organize themselves into hierarchies according to their willingness and ability to fight for resources (Friend and Polan, 1974; Phillips and Rind, 2002). Grazing dairy cows will often compete for the best available grazing area (Phillips and Rind, 2002). Miller and Wood-Gush (1991) found that indoor housed cattle showed a higher level of agonistic behavior compared to cattle kept on pasture. Reduced incidence of agonistic behavior on pasture is viewed to be the result of increased social space and, therefore, more opportunity to avoid dominant individuals (Boe and Faerevik, 2003). For group-housed dairy cattle, it has been shown that the majority of aggressive displacements seem to be caused by competition for a resource (e.g. feeding place) (Wierenga, 1990). Several other researchers have indicated that increased aggressive behavior is associated with the feeding area, specifically around the time of feed delivery (Friend and Polan, 1974; Jezierski and Podluzny, 1984; Miller and Wood-Gush, 1991). Empel et al. (1993) noted that there was a high incidence of fighting for feed access in a

loose-housing system. These latter researchers also noted that the incidence of aggressive behavior decreased in the hours after delivery of feed.

Increased competition among cows at the feeder may lead to increased incidence of injuries while feeding (Grant and Albright, 2001) any may cause some cows to modify their feeding times to avoid aggressive interactions (Miller and Wood-Gush, 1991). Manson and Appleby (1990) demonstrated that when a competitive situation exists at the feed bunk, dominant cows spend more time eating than cows of lower social rank. In this case, subordinate cows would likely be most limited in their access to feed during peak-feeding times (Friend and Polan, 1974). It has also been suggested that feed access may be more important than the actual amount of nutrients provided (Albright, 1993). It follows that allowing cows to access feed when they want to feed will allow them to maximize their feed intake.

Wierenga (1990) suggested that both management and housing can affect the relationships between animals, and therefore, can affect the roles of social dominance when animals are kept indoors. Since both social hierarchies and competition for feed affect feeding behavior (Grant and Albright, 2001), it follows that both feeding management and feed area design in group-housed dairy systems have the potential to influence the feeding behavior of lactating dairy cattle.

1.5 FEEDING MANAGEMENT

The grazing behavior of cattle has been studied for many years. In a paper on the behavior and grazing habits of cattle, Johnstone-Wallace and Kennedy (1944) cited a report from 1797 describing the grazing habits of cattle. Since that time, many other researchers have reported on the behavior of the grazing ruminant (e.g. Hardison et al., 1956; Sheppard et al.,

1957; Ruckebusch and Bueno, 1978; Rook and Huckle, 1995). It has been concluded that grazing cattle typically display feeding patterns in which the majority of grazing occurs during the daylight hours (Castle et al., 1950; Sheppard et al., 1957; Hafez and Bouissou, 1975). Further, cattle are described as having a crepuscular grazing pattern (Albright, 1993), in which the most continuous grazing periods occur around sunrise and sunset (Castle et al., 1950; Sheppard et al., 1957; Hafez and Bouissou, 1975). Similarly, several researchers have shown a diurnal pattern of feeding activity, with peaks occurring around the time of sunrise and sunset, in beef feedlot cattle (Ray and Roubicek, 1971), tie-stall housed dairy cattle (Vasilatos and Wangsness, 1980), and free-stall housed dairy cattle (DeVries et al., 2003). For housed dairy cattle, times of peak feeding activity are also often associated with the time of feed delivery and milking. Both Vasilatos and Wangsness (1980) and Haley et al. (2000) reported that when animals were housed individually in tie stalls they tended to eat most during the day; with peak feeding activity occurring immediately following milking and feed delivery. These responses to milking and feeding have also been demonstrated in cows that are free-stall housed who consume feed in a group setting (e.g. Tanida et al., 1984; Wagner-Storch and Palmer, 2003; DeVries et al., 2003).

The natural tendency for cows to continually sort the feed and push it away while eating from a feed bunk results in much of the feed being tossed forward where it is no longer within reach of the animal. Thus producers commonly push the feed closer to the cows (push-up) in between feedings as a means of ensuring that cows have continuous access to the feed. It is commonly believed that the pushing up of feed also acts as a stimulant for feeding activity. In an observational study by Menzi and Chase (1994), it was noted that the number of cows feeding increased after feed push-up, however they concluded that feed push-ups had “minor and brief effects” in comparison to milking on the feed bunk attendance. In a more recent study DeVries et

al. (2003) demonstrated that the large peaks in feed bunk attendance corresponded to times of milking and delivery of fresh feed, with the response to feed push-up being substantially less.

It is interesting to note that in many studies (e.g. Vasilatos and Wangsness, 1980; DeVries et al., 2003), as well as at commercial free stall dairies, the management practices of milking and feeding typically occur at the same time. Further, these activities typically occur in the early morning and late afternoon, which are the times when dairy cattle are traditionally believed to engage in most of their feeding activity. This makes it difficult to determine whether it is the management practice of feed delivery, the act of returning from milking, or an innate crepuscular behavior which is acting as the primary influence determining the daily feeding pattern of lactating dairy cows.

During the past few years there has been increased interest in determining the effects that frequency of feed delivery has on lactating dairy cattle. Previous research in this area has been focused on the effects on milk production and dry matter intake (DMI) (see, for example, Gibson, 1984; Nocek and Braund, 1985; Shabi et al., 1999; Dhiman et al., 2002). Gibson (1984) summarized 35 experiments on the effects of frequency of feeding on lactating dairy cows, and noted variable results. This variation was attributed to differences in methodology, for example: experimental procedures, breeds of cows, diet composition and feeding level. Furthermore, the majority of the experimental conditions described by this researcher (e.g. individual tie-stall housing, low milk production) may not be applicable to today's high production, modern dairy operations. Since the review by Gibson (1984), there have been several additional studies on the effects of frequency of feed delivery on dairy cattle (e.g. Nocek and Braund, 1985; Shabi et al., 1999; Dhiman et al., 2002). Unfortunately, the findings varied between studies and, furthermore, they were all undertaken with individually-housed animals.

It can be surmised that the frequency of feed delivery may have different effects for group-housed cattle, specifically due to the synchronization of behavior that exists in that setting. In a recent study by Phillips and Rind (2001), the effects of frequency of feed delivery on group-housed cattle were investigated by comparing once daily to four times a day feed delivery. The results indicated no change in feed intake or time spent feeding. Unfortunately, these authors based their feeding behavior data on only 1 d of observations per treatment and there is considerable day-to-day variation in feeding behavior (Dado and Allen, 1994). Further, the DMI and production level of the cows were very low in comparison to that observed on many modern dairy operations. Cows with low DMI and milk production may not have the same motivation to feed and, therefore, may not respond to increased frequency of feed delivery by increasing their feeding time as much as cows with high DMI and milk production. With the exception of the Phillips and Rind (2001) study, there is little indication in the literature as to the effect of frequency of feed delivery on the behavior of group-housed lactating dairy cattle, necessitating further quality research in this area.

1.6 FEED AREA DESIGN

One of the specific objectives of cattle housing is to provide a comfortable environment and adequate food and water supplies to meet the behavioral and physiological needs of the animals (Phillips, 2001). It has been suggested that well designed systems allow for normal feeding behavior, which in turn allow for improved cow comfort and well-being (Grant and Albright, 2000). There are several components of the feeding environment that potentially influence cow comfort and the ability of cows to access feed when they want to, including the amount of available feed bunk space and the physical design of the feeding area.

1.6.1 Feed bunk space

The amount of feed bunk space allocated per cow may affect the feeding behavior of cows. It has been typically recommended that each cow have approximately 0.6 m of linear feed bunk space to ensure that all animals can feed simultaneously (Grant and Albright, 2001). Some researchers have suggested that this recommendation is overly cautious, given that cows can show similar feed intake and milk production with space allotments much lower than the recommended level (e.g. Friend and Polan, 1974, Friend et al., 1977; Menzi and Chase, 1994). In fact, some researchers have concluded that grouped cows can be kept with as little as 0.2 m of feed bunk space/cow without adversely affecting DMI or milk production (e.g. Friend et al., 1977; Collis et al., 1980).

However, the tendency for dairy cattle to synchronize their behavior, including their feeding behavior, brings into question work advocating the use of only 0.2 m of linear bunk space/cow. It can be speculated that lack of feed bunk space may be a contributing factor to the loss of synchrony when cattle are group-housed indoors. For example, Friend and Polan (1974) reported that only 66% of cows could eat at one time when provided with 0.5 m of feed bunk space and DeVries et al. (2003) showed that less than 70% of animals fed simultaneously when given 0.6 m of feed bunk space/cow. These findings suggest that space availability, and the associated increase in competitive behavior, limits the ability of cows to synchronize their feeding behavior, particularly during popular eating times. Based on this, it would be interesting to know if increasing the amount of feed bunk space above that typically given could increase the ability of cows to access feed at peak feeding periods, particularly those subordinate cows who may be most affected by competition.

1.6.2 Feed barrier design

Fence-line feeding is commonly used when feeding group-housed dairy cows at commercial dairies. This type of feeding system was developed to allow for good feed access while preventing the animals from walking and defecating on the feed. However, the design of the physical barrier separating the cows from the feed may have unintended consequences, such as limiting the cows' ability to freely access feed and increasing the frequency of aggressive interactions at the feeder. This is of particular interest since work undertaken with other domesticated species, such as pigs, indicates that the configuration of feeding spaces can have profound effects on feeding competition (e.g. Andersen et al., 1999).

Since the introduction of free-stall housing systems, two types of feed-line barriers have become common: headlocks, which are self-locking stanchions that provide metal bar divisions between the necks of cows, and post and rail, which provides an open feeding area with a metal neck-rail to prevent cows from moving into the feed bunk (see Figure 1.3). In modern dairy systems, cattle are commonly separated from their feed by a post-and-rail feed barrier system, which allows the cows to move their head to and from the feed as well as from side to side. For cattle, that often displace one another while feeding by swinging and butting with the head, modifications that restrict contact between the head of a cow and the head and/or body of an adjacent cow may be particularly effective in reducing competition. A barrier design that provides some sort of separation between cows (e.g. headlocks) may reduce competition by making it harder for cows to displace each other from the feed bunk. Unfortunately, there has been little research to substantiate this idea. In fact, very limited data are available comparing different feed barrier designs used in dairy cattle housing.

Some researchers (e.g. Batchelder, 2000; Brouk et al., 2003) have compared headlocks to more open feed barriers such as the post-and-rail design, but have focused on the effects on DMI

rather than feeding or social behavior. Batchelder (2000) compared headlocks to a post-and-rail barrier at two different stocking densities (0.72 and 0.55 m of linear bunk space/cow), and found that DMI was 3 to 6% higher when using the post-and-rail barrier design. In contrast, Brouk et al. (2003) found no difference in DMI between the two barriers. In both these studies, limited treatment replicates were used, and thus the results should be regarded with caution. Further, these researchers did not investigate how the barrier design affects the feeding and social behavior of the cows. Two studies have recently been completed (Endres et al., 2005; Huzzey et al., 2006) comparing the effects of these barriers on the feeding and social behavior of dairy cattle. In the study by Endres et al. (2005), no effect of barrier on feeding time was found, however, Huzzey et al. (2006) found that cows were able to increase their feeding time with the post-and-rail barrier. Despite this, the researchers in both studies found that the use of the headlock barrier significantly reduced the incidence of aggressive displacements at the feed bunk. Unfortunately, aggressive behavior was still noted during both experiments between cows fed using the headlock barrier, indicating that the neck division may not provide full protection.

It has been suggested that cows may feel more protected when a physical separation exists between them at a feed bunk (Konggaard, 1983). This extra protection may create a more comfortable feeding environment, allowing cows to feed when they want to, which in turn, may allow them to maximize their feed intake. Several pig researchers have shown that larger (i.e. more than just the neck) dividers between adjacent feeding animals can have profound effects on reducing feeding competition. For example, Baxter (1986) found that aggressive behavior was reduced when pigs were fed with a head-barrier system and, further, virtually eliminated aggressive behavior when the head and shoulder barrier was installed. Andersen et al. (1999) also studied the effects of different feeding arrangements (body partitions, shoulder partitions,

and no partitions) on aggressive behavior of pigs. They found that a feeding arrangement with body partitions resulted in the least aggression and displacements at the feed trough.

Beyond the studies comparing headlock barriers to open post-and-rail type barriers, there are limited data on how the configuration of feeding spaces affects dairy cattle. Bouissou (1970) compared the effects of different types of physical barriers on the feeding times of hungry cows positioned side-by-side at the feed bunk. This researcher found that divisions at the feed bunk separating the bodies and, particularly, the heads of adjacently feeding cows allow subordinate cows to feed for longer periods of time. Unfortunately, this research was conducted using only two animals at a time, so the effects of the divisions in a larger group of cows are unknown. Further, the cows in that study were horned, which may explain why the head separations were the most effective treatments.

Since the study by Bouissou (1970), no research has addressed the effects that large divisions (i.e. head and/or body) between adjacent cows may have on the feeding and social behavior of group-housed cattle. This research is essential to firstly understand how feed area design influences the behavior of dairy cattle, and secondly to make recommendations to improve feeding conditions at the feed bunk.

1.7 OBJECTIVES

This review has identified some important gaps in the literature on dairy cattle feeding behavior. In particular, there is a lack of research on the management and design of the feeding area for lactating dairy cows that are housed in social environments where competition for food resources occurs. For this reason, the overall objective of this dissertation was to determine how feeding management and feed area design influence the behavior of group-housed lactating dairy cows. I addressed this objective using a four step approach:

- 1) define feeding behavior measures and determine which of these measures are most repeatable and reliable for detecting treatment differences,
- 2) assess the factors controlling the feeding patterns of group-housed lactating dairy cows,
- 3) assess the effects of feeding management on the behavior of group-housed lactating dairy cows, and
- 4) assess the effects of feed area design on the behavior of group-housed lactating dairy cows.

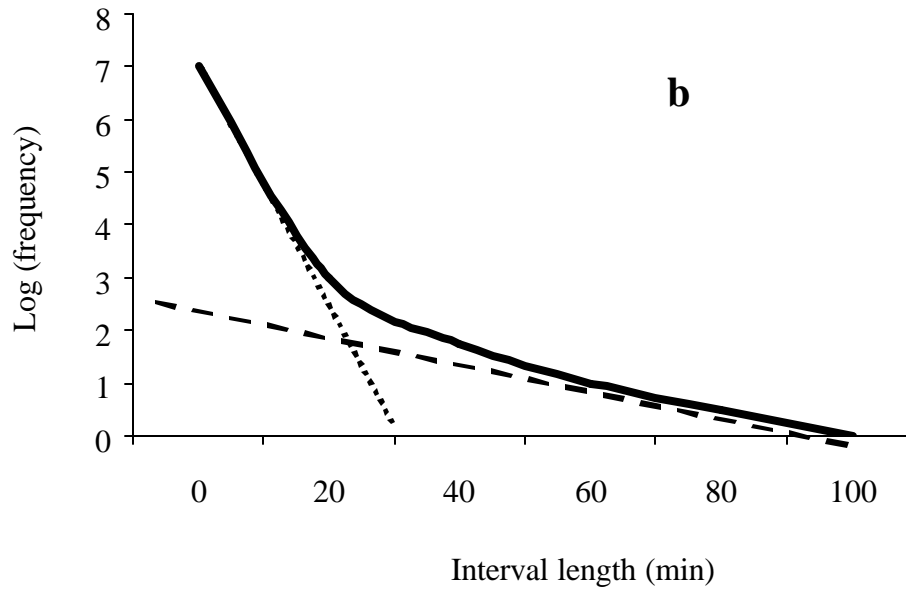
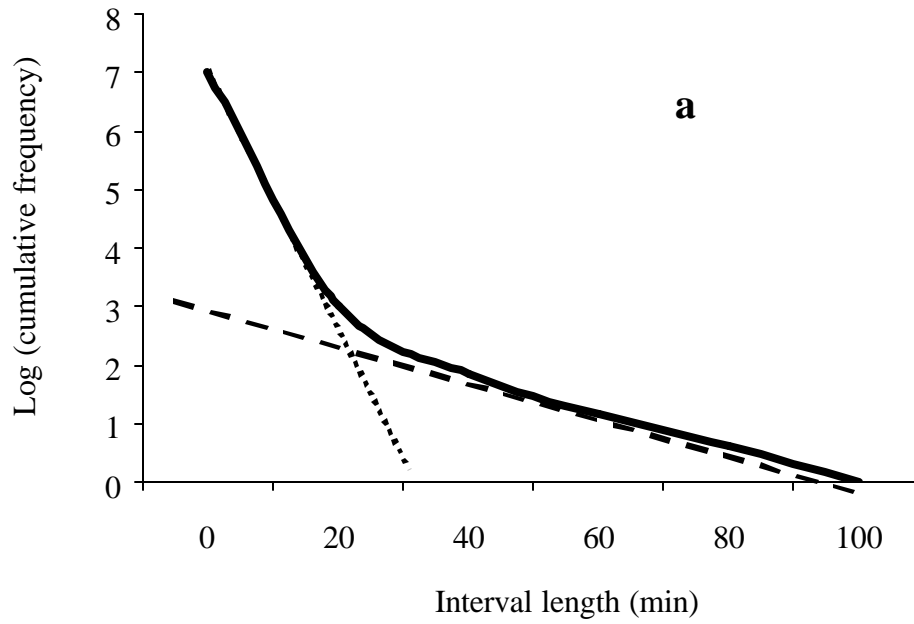

Figure 1.1. (a) Log-survivorship and (b) log-frequency curves showing the fast process (line with small dashes), slow process (line with large dashes), and the combined curve. The meal criterion is the interval at which the slow and fast process lines intersect. Note that the change from the log-survivorship curve to the log-frequency does not dramatically impact the criterion interval.

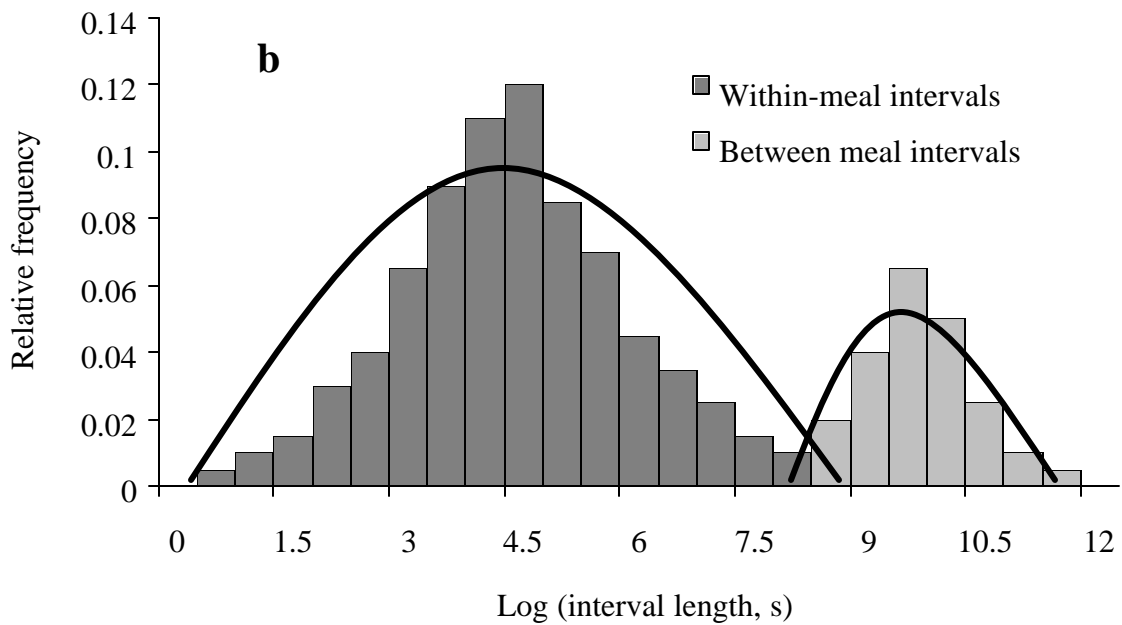
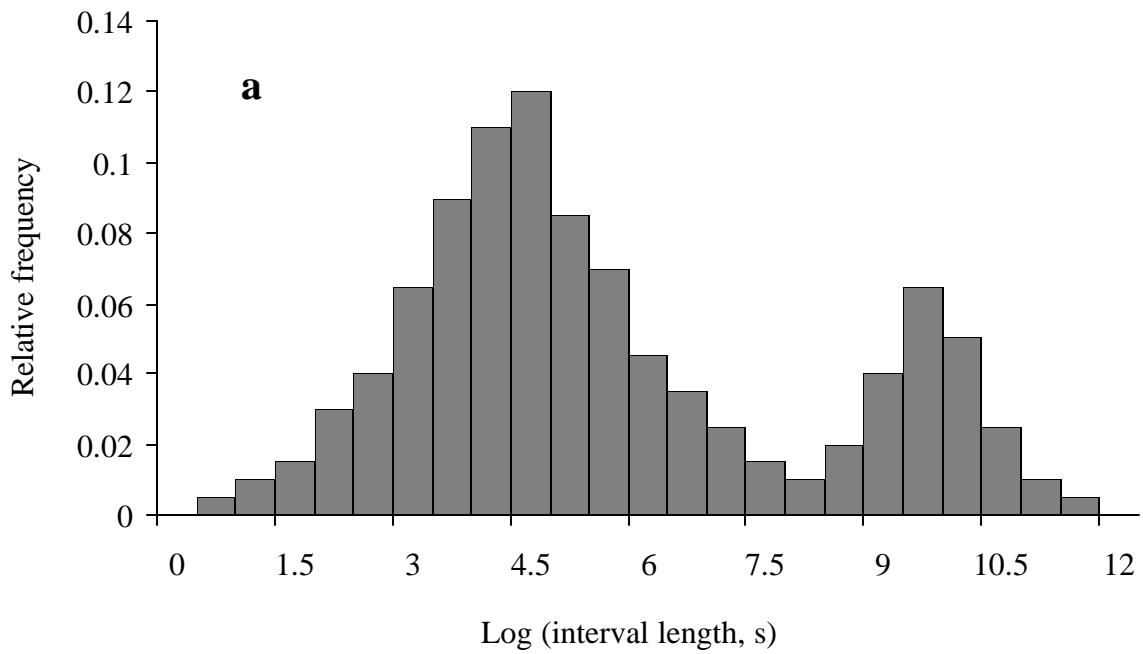

Figure 1.2. (a) The frequency distribution of the log-transformed intervals between feeding bouts. (b) The frequency distribution of the log-transformed intervals fitted with a mixture of two normal distributions, effectively separating the within meal intervals and the between meal intervals. The meal criterion is the log interval at which the two curves intersect.

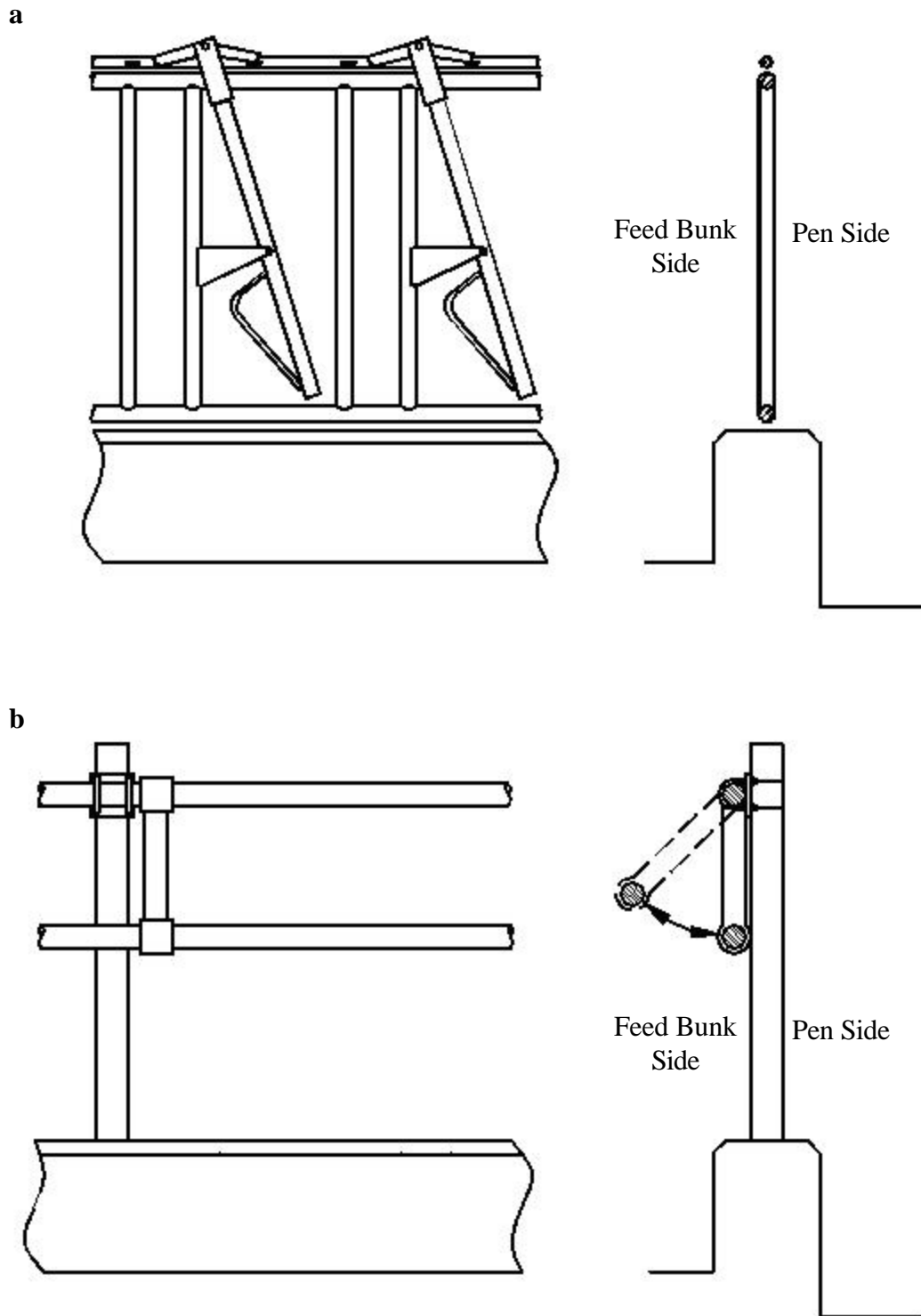

Figure 1.3. Example of front view and cross-sectional view of a portion of a headlock (a) and a post-and-rail (b) feed barrier (adapted from Huzzey et al., 2006).

1.8 REFERENCES

- Albright, J. L. 1993. Feeding behavior of dairy cattle. *J. Dairy Sci.* 76:485-498.
- Allen, M. S. 2000. Effects of diet on short-term regulation of feed intake by lactating dairy cattle. *J. Dairy Sci.* 83:1598-1624.
- Anderson, I. L., K. E. Boe, and A. L. Kristiansen. 1999. The influence of different feeding arrangements and food type on competition at feeding in pregnant sows. *Appl. Anim. Beh. Sci.* 65:91-104.
- Batchelder, T. L. 2000. The impact of head gates and overcrowding on production and behavior patterns of lactating dairy cows. Pages 325-330 in the Proceedings of the 2000 Dairy Housing and Equipment Systems: Managing and planning for profitability. NRAES - 129, Ithaca, NY.
- Baxter, M. R. 1986. The design of the feeding environment for the pig. Ph.D. Diss., University of Aberdeen, UK.
- Berdoy, M. 1993. Defining bouts of behaviour: a three process model. *Anim. Beh.* 46:387-396.
- Boe, K. E., and G. Faerevik. 2003. Grouping and social preferences in calves, heifers and cows. *Appl. Anim. Beh. Sci.* 80:175-190.
- Bouissou, M.-F. 1970. Role du contact physique dans la manifestation des relations hierarchiques chez les bovines. Consequences pratiques. *Annales de Zootechnie.* 19:279-285.
- Brouk, M. J., J. F. Smith, and J. P. Harner, III. 2003. Effect of feedline barrier on feed intake and milk production of dairy cattle. Pages 192-195 in the Proceedings of the Fifth International Dairy Housing Conference. K. A. Janni, ed. American Society of Agricultural Engineers, St. Josephs, Michigan.
- Castle, M. E., A. S. Foot, and R. J. Halley. 1950. Some observations on the behavior of dairy cattle with particular reference to grazing. *J. Dairy Res.* 17:215-230.
- Cheeke, P. R. 1999. Applied animal nutrition. Feeds and feeding. 2nd edition. Prentice Hall. Upper Saddle River, New Jersey.
- Clutton-Brock, J. 1999. A natural history of domesticated mammals. Cambridge University Press. Cambridge, UK.
- Collis, K. A., M. J. Vagg, P. T. Gleed, C. M. Copp, and B. F. Sansom. 1980. The effects of reducing manger space on dairy cow behavior and production. *Vet. Rec.* 107:197-198.
- Curtis, S. E., and K. A. Houpt. 1983. Animal ethology: its emergence in animal science. *J. Anim. Sci.* 57 (Suppl. 2):234-247.

- Dado, R. G., and M. S. Allen. 1993. Continuous computer acquisition of feed and water intakes, chewing, reticular motility, and ruminal pH of cattle. *J. Dairy. Sci.* 76:1589-1600.
- Dado, R. G., and M. S. Allen. 1994. Variation in and relationships among feeding, chewing, and drinking variables for lactating dairy cows. *J. Dairy Sci.* 77:132-144.
- DeVries, T. J., M. A. G. von Keyserlingk, and K. A. Beauchemin. 2003. Diurnal feeding pattern of lactating dairy cows. *J. Dairy Sci.* 86:4079-4082.
- Dhiman, T. R., M. S. Zaman, I. S. MacQueen, and R. L. Boman. 2002. Influence of corn processing and frequency of feeding on cow performance. *J. Dairy Sci.* 85:217-226.
- Empel, W., T. Jezierski, P. Brzozowski, H. Markiewicz-Grabowska, K. Gimzewska, and T. Kolakowski. 1993. Behaviour of dairy cows within three hours after feed supply. I. Influence of housing type and time elapsing after feed supply. *Animal Science Papers and Reports.* 11:301-309.
- Endres, M. I., T. J. DeVries, M. A. G. von Keyserlingk, and D. M. Weary. 2005. Effect of feed barrier design on the behavior of loose-housed lactating dairy cows. *J. Dairy Sci.* 88:2377-2380.
- Forbes, J. M. 1995. *Voluntary Food Intake and Diet Selection in Farm Animals.* CAB Int., Wallingford, United Kingdom.
- Forbes, J. M. 2000. Physiological and metabolic aspects of feed intake control. Pages 319-333 in *Farm Animal Metabolism and Nutrition.* J. P. F. D'Mello, ed. CABI Publishing, Wallingford, Oxon, UK.
- Friend, T. H., and C. E. Polan. 1974. Social rank, feeding behavior, and free stall utilization by dairy cattle. *J. Dairy Sci.* 57:1214-1220.
- Friend, T. H., C. E. Polan, and M. L. McGilliard. 1977. Free stall and feed bunk requirements relative to behavior, production and individual feed intake in dairy cows. *J. Dairy Sci.* 60:108-116.
- Gibb, D. J., T. A. McAllister, C. Huisma, and R. D. Wiedmeierer. 1998. Bunk attendance of feedlot cattle monitored with radio frequency technology. *Can. J. Anim. Sci.* 78:707-710.
- Gibson, J. P. 1984. The effects of frequency of feeding on milk production of dairy cattle: An analysis of published results. *Anim. Prod.* 38:181-189.
- Grant, R. J., and J. L. Albright. 2000. Feeding Behaviour. Pages 365-382 in *Farm Animal Metabolism and Nutrition.* J. P. F. D'Mello, ed. CABI Publishing, Wallingford, Oxon, UK.
- Grant, R. J., and J. L. Albright. 2001. Effect of animal grouping on feeding behavior and intake of dairy cattle. *J. Dairy Sci.* 84 (E. Suppl.):E156-E163.

- Hafez, E. S. E., and M. F. Bouissou 1975. The behaviour of cattle. Pages 203-245 in *The behaviour of domestic animals*. 3rd ed. E. S. E. Hafez, ed. Bailliere Tindall, London, UK.
- Haley, D. B., J. Rushen, and A. M. de Passille. 2000. Behavioural indicators of cow comfort: activity and resting behaviour of dairy cows in two types of housing. *Can. J. Anim. Sci.* 80:257-263.
- Harb, M. Y., V. S. Reynolds, and R. C. Campling. 1985. Eating behaviour, social dominance and voluntary intake of silage in group-fed milking cattle. *Grass and Forage Science*. 40:113-118.
- Hardison, W. A., H. L. Fisher, G. C. Graf, and N. R. Thompson. 1956. Some observations on the behavior of grazing lactating cows. *J. Dairy Sci.* 39:1735-1741.
- Heizer, E. E., V. R. Smith, and C. E. Zehner. 1953. A summary of studies comparing stanchion and loose housing barns. *J. Dairy Sci.* 36:281-292.
- Huzzey, J. M., T. J. DeVries, P. Valois, and M. A. G. von Keyserlingk. 2006. Stocking density and feed barrier design affect the feeding and social behavior of dairy cattle. *J. Dairy Sci.* 89:126-133.
- Ingvartsen, K. L., and J. B. Andersen. 2000. Integration of metabolism and intake regulation: a review focusing on periparturient animals. *J. Dairy Sci.* 83:1572-1597.
- Jeziarski, T. A., and M. Podluzny. 1984. A quantitative analysis of social behaviour of different crossbreds of dairy cattle kept in loose housing and its relationship to productivity. *Appl. Anim. Beh. Sci.* 13:31-40.
- Johnstone-Wallace, D. B., and K. Kennedy. 1944. Grazing management practices and their relationship to the behavior and grazing habits of cattle. *J. Agr. Sci.* 34:190-197.
- Konggaard, S. P. 1983. Feeding conditions in relation to welfare for dairy cows in loose-housing systems. Pages 272-280 in S. H. Baxter, M. R. Baxter and J. A. D. MacCormack, eds., *Farm Animal Housing and Welfare*. Martinus Nijhoff, Dordrecht, The Netherlands.
- Langton, S. D., D. Collett, and R. M. Sibly. 1995. Splitting behaviour into bouts: a maximum likelihood approach. *Behaviour*. 132: 781-799.
- Machlis, L. 1977. An analysis of the temporal patterning of pecking in chicks. *Behaviour*. 63:1-70.
- Manson, F. J., and M. C. Appleby. 1990. Spacing of dairy cows at a food trough. *Appl. Anim. Beh. Sci.* 26:69-81.
- Mayes, E., and P. Duncan. 1986. Temporal patterns of feeding behaviour in free-ranging horses. *Behaviour*. 96:105-129.

- McDonald, P., R. A. Edwards, J. F. D. Greenhalgh, and C. A. Morgan. 2002. *Animal nutrition*. 6th edition. Pearson Education Limited. Harlow, UK.
- Menzi, W. Jr., and L. E. Chase. 1994. Feeding behavior of cows housed in free stall barns. Pages 829-833 in *Dairy Systems for the 21st Century*. American Society of Agricultural Engineers. St. Joseph, MI.
- Metz, J. H. M. 1975. *Time patterns of feeding and rumination in domestic cattle*. Wageningen: Communications Agricultural University.
- Miller, K., and D. G. M. Wood-Gush. 1991. Some effects of housing on the social behaviour of dairy cows. *Anim. Prod.* 53:271-278.
- National Research Council. 2001. *Nutrient requirements of dairy cattle*. 7th rev. ed. National Academy Press, Washington DC.
- Nielsen, B. L. 1999. On the interpretation of feeding behaviour measures and the use of feeding rate as an indicator of social restraint. *Appl. Anim. Behav. Sci.* 63:79-91.
- Nocek, J. E., and D. G. Braund. 1985. Effect of feeding frequency on diurnal dry matter and water consumption, liquid dilution rate, and milk yield in first lactation. *J. Dairy Sci.* 68:2238-2247.
- O'Connell, J., P. S. Giller, and W. Meaney. 1989. A comparison of dairy cattle behavioural patterns at pasture and during confinement. *Irish J. Agr. Res.* 28:65-72.
- Phillips, C. J. C. 2001. *Principles of cattle production*. CABI Publishing, CAB International. Wallingford, UK.
- Phillips, C. 2002. *Cattle behaviour and welfare*. 2nd edition. Blackwell Publishing Company. Oxford, UK.
- Phillips, C. J. C., and M. I. Rind. 2001. The effects of frequency of feeding a total mixed ratio on the production and behavior of dairy cows. *J. Dairy Sci.* 84:1979-1987.
- Phillips, C. J. C., and M. I. Rind. 2002. The effects of social dominance on the production and behavior of grazing dairy cows offered forage supplements. *J. Dairy Sci.* 85:51-59.
- Ray, D. E., and C. B. Roubicek, 1971. Behavior of feedlot cattle during two seasons. *J. Anim. Sci.* 33:72-76.
- Rook, A. J., and C. A. Huckle. 1995. Synchronization of ingestive behaviour by grazing dairy cows. *Anim. Sci.* 60:25-30.
- Ruckebusch, Y., and L. Bueno. 1978. An analysis of ingestive behaviour and activity of cattle under field conditions. *Appl. Anim. Ethol.* 4:301-313.

Schleidt, W. M. 1965. Gaussian interval distributions in spontaneously occurring innate behaviour. *Nature*. 206:1061-1062.

Senn, M., B. Durst, A. Kaufmann, and W. Langhans. 1995. Feeding patterns of lactating cows of three different breeds fed hay, corn silage, and grass silage. *Physiology and Behavior*. 58:229-236.

Shabi, Z., I. Bruckental, S. Zamwell, H. Tagari, and A. Arieli. 1999. Effects of extrusion of grain and feeding frequency on rumen fermentation, nutrient digestibility, and milk yield and composition in dairy cows. *J. Dairy Sci.* 82: 1252-1260.

Sheppard, A. J., R. E. Blaser, and C. M. Kincaid. 1957. The grazing habits of beef cattle on pasture. *J. Anim. Sci.* 16:681-687.

Sibly, R. M., H. M. R. Nott, and D. J. Fletcher. 1990. Splitting behaviour into bouts. *Anim. Behav.* 39:63-69.

Simpson, S. J. 1990. The pattern of feeding. Pages 73-103 in: *Biology of Grasshoppers*. R. F. Chapman and A. Joern, eds. John Wiley & Sons., New York.

Simpson, S. J., and A. R. Ludlow. 1986. Why locusts start to feed: a comparison of causal factors. *Anim. Beh.* 34:480-496.

Sitter, R. 1999. *Introduction to animal behavior*. Brooks/Cole Publishing Company. Pacific Grove, California, USA.

Slater, P. J. B., and N. P. Lester. 1982. Minimising errors in splitting behaviour into bouts. *Behaviour*. 79:153-161.

Sowell, B. F., M. E. Branine, J. G. P. Bowman, M. E. Hubbert, H. E. Sherwood, and W. Quimby. 1999. Feeding and watering behavior of healthy and morbid steers in a commercial feedlot. *J. Anim. Sci.* 77:1105-1112.

Tanida, H., L. V. Swanson, and W. D. Hohenboken. 1984. Effect of artificial photoperiod on eating behavior and other behavioral observations of dairy cows. *J. Dairy Sci.* 67:585-591.

Tolkamp, B. J., and I. Kyriazakis. 1999a. To split behaviour into bouts, log-transform the intervals. *Anim. Behav.* 57:807-817.

Tolkamp, B. J., and I. Kyriazakis. 1999b. A comparison of five methods that estimate meal criteria for cattle. *Anim. Sci.* 69:501-514.

Tolkamp, B. J., D. J. Allcroft, E. J. Austin, B. L. Nielsen, and I. Kyriazakis. 1998. Satiety splits feeding behaviour into bouts. *J. Theor. Biol.* 194:235-250.

- Tolkamp, B. J., D. P. N. Schweitzer, and I. Kyriazakis. 2000. The biologically relevant unit for the analysis of short-term feeding behavior of dairy cows. *J. Dairy Sci.* 83:2057-2068.
- USDA. 1996. Part I: Reference of 1996 dairy management. USDA:APHIS:VS, CEAH, National Animal Health Monitoring System, Fort Collins, USA.
- USDA. 2002. Part I: Reference of dairy health and management in the United States. USDA:APHIS:VS, CEAH, National Animal Health Monitoring System, Fort Collins, USA.
- Van Soest, P. J. 1994. Nutritional ecology of the ruminant. 2nd edition. Cornell University Press. Ithaca, New York.
- Vasilatos, R., and P. J. Wangsness. 1980. Feeding behavior of lactating dairy cows as measured by time-lapse photography. *J. Dairy Sci.* 63:412-416.
- Wagner-Storch, A. M., and R. W. Palmer. 2003. Feeding behavior, milking behavior, and milk yields of cows milked in a parlor versus an automatic milking system. *J. Dairy Sci.* 86:1494-1502.
- Wangsness, P. J., L. E. Chase, A. D. Peterson, T. G. Hartsock, D. J. Kellmel, and B. R. Baumgardt. 1976. System for monitoring feeding behavior of sheep. *J. Anim. Sci.* 42:1544-1549.
- Wierenga, H. K. 1990. Social dominance in dairy cattle and the influences of housing and management. *Appl. Anim. Beh. Sci.* 27:201-229.
- Yeates, M. P., B. J. Tolkamp, D. J. Allcroft, and I. Kyriazakis. 2001. The use of mixed distribution models to determine bout criteria for analysis of animal behaviour. *J. Theor. Biol.* 213:413-425.

CHAPTER 2: Measuring the feeding behavior of lactating dairy cows in early to peak lactation^{1?}

2.1 INTRODUCTION

Promoting feed intake by lactating dairy cattle is critical in terms of improving milk production, health, and body condition of the animal (Grant and Albright, 1995). Research in this area requires knowledge of both nutrition and behavior (Nielsen, 1999); however, the difficulty in manually collecting behavioral data at the time of feeding has limited the extent of this research (Friggens et al., 1998). The use of time-lapsed video recordings (Vasilatos and Wangsness, 1980; Menzi and Chase, 1994) and recent advances in the development of computerized recording systems have resulted in a renewed interest in obtaining information on feeding behavior (Gibb et al., 1998).

Grant and Albright (2000) reviewed much of this literature and concluded that management factors such as grouping strategy, feeding system design and apparatus, composition and physical characteristics of the feed being consumed, as well as social hierarchy and competition for food and water all influenced the feeding behavior of cattle. However, there has been little work on more basic issues such as the temporal patterning of feeding, and how feeding bouts are divided into meals. This basic work can provide a solid basis for future applied studies by showing what measures of feeding behavior are most repeatable and how alternative measures are correlated.

Animals typically divide their feeding time into a series of meals separated by non-feeding intervals (Forbes, 1995), and this is also the case with dairy cows (Tolkamp et al., 1998; 2000). However, identifying which intervals are between meals, versus shorter gaps within a

¹A version of this chapter has been published. DeVries, T. J., M. A. G. von Keyserlingk, D. M. Weary, and K. A. Beauchemin. 2003. Measuring the feeding behavior of lactating dairy cows in early to peak lactation. *J. Dairy Sci.* 86:3354-3361.

meal, can be problematic. Consider the types of intervals that can occur between visits to the feed bunk. In some cases the cow may simply lift her head for a few seconds. In others she may withdraw from the bunk for less than a minute or so when, for example, she is displaced by a dominant cow and must move to another location on the bunk or she may leave for several minutes when she visits the water trough elsewhere in the pen. Finally, in cases where she goes to lie down in a stall she may be away for an extended period of time.

In their pioneering work determining which intervals are between meals and which are within meals, Tolkamp and colleagues (Tolkamp et al., 1998; Tolkamp and Kyriazakis, 1999; Yeates et al., 2001) used the distribution of a large sample of intervals to define objectively the meal criterion (i.e. the minimum interval between visits to consider the next feed bunk visit as being part of a new meal). These authors argued that previous approaches to this problem (e.g. Slater and Lester, 1982; Sibly et al., 1990; Langton et al., 1995) had assumed incorrectly that the probability of an animal initiating a meal was independent of the time since the last meal. Tolkamp et al. (1998) showed that this issue could be more appropriately addressed by plotting the frequency distribution of intervals (typically log transformed) and using discontinuities in the distribution to determine objectively which intervals were within meals and which were between meals.

The research by Tolkamp and colleagues (Tolkamp et al., 1998; Tolkamp and Kyriazakis, 1999; Yeates et al., 2001) was based on the behavior of cows restricted to eating from specific feeding stations and thus, may not account for all of the competitive interactions that occur during feeding in commercial loose-housed systems. One aim of the current study was to replicate this work using free-stall housed cows fed via a feed bunk. In addition, no work has examined the within cow repeatability of various measures of feeding behavior. This is

important, as future research will be limited if based on measures that are only weakly repeatable. Thus, a second aim of this study was to use repeated observations of various measures to determine which of these measures are most repeatable. Finally, a third objective of the current study was to describe changes in feeding behavior from early to peak lactation.

2.2 MATERIALS AND METHODS

2.2.1 Experimental Design

Ten primiparous and 11 multiparous lactating Holstein cows, which had a 305-d milk production of $11,000 \pm 2916$ (mean \pm SD) kg, were housed together as a single group and monitored using the GrowSafe feed bunk monitoring system from early to peak lactation. The cows were housed in a free-stall barn located at The University of British Columbia Dairy Education and Research Centre (Agassiz, BC, Canada) and were managed according to the guidelines set by the Canadian Council on Animal Care (1993). Each animal had access to a free stall that was filled with deep-bedded sand. For the entire experiment the cows were fed a TMR consisting of 20% corn silage, 20% grass silage, 7% alfalfa hay, 3% grass hay, and 50% grain concentrate mash on a DM basis. The TMR was formulated according to the NRC (2001) nutrient requirement recommendations for high producing dairy cows. Cows were fed from a feed bunk (0.6 m of space/cow) with access via a neck rail. Animals were fed daily at approximately 0600 h and 1515 h and were milked at approximately 0530 h and 1530 h daily. Feeding behavior of all cows was recorded for a minimum of 8 d for three time periods between early and peak lactation. Data collection during Period 1, Period 2, and Period 3 began when cows were at 35 ± 16 DIM (mean \pm SD), 57 ± 16 DIM, and 94 ± 16 DIM, respectively. The experiment was conducted between September 23, 2001 and December 6, 2001.

2.2.2 Feeding Behavior Data Collection

An electronic feed bunk monitoring system (GrowSafe Systems Ltd., Airdrie, AB, Canada), originally described by Sowell et al. (1998), and modified and validated by Schwartzkopf-Genswein et al. (1999) was used in this study. It was modified further in the present study to allow for data transfer from the reader panel to the computer via radio frequency. Its use with cattle fed via a feed bunk also required installation of the antenna mats (each 7.2 m long and 0.75 m wide) directly onto the floor of the feed bunk adjacent to the tombstone; thereby, allowing the feed to be delivered on top of the mats. All experimental animals were fitted with a passive transponder, which was encased in a plastic ear tag (All Flex, Inc., Dallas TX) and attached to the bottom of the neck collar. When a cow placed her head under the neck rail and over the feed such that the transponder came within 50 cm of the antenna mat, a signal was immediately transmitted to the reader panel. The reader panel continued to record the presence (a 'hit') of each transponder every 6 s for as long as the transponder was within the read range of the antenna. The data (transponder number and time stamp) were downloaded continuously via radio frequency to a computer housed approximately 100 m from the panel. The computer was equipped with GrowSafe feed bunk monitoring software version 6.38.

2.2.3 Feeding Behavior Analysis

The meal criteria were calculated using the frequency distribution of the \log_{10} -transformed interval lengths between hits for each individual animal for each time period. The three time periods were chosen to capture possible changes in feeding behavior from early to peak lactation. Although a minimum of 8 d of feeding behavior data were collected for each period, in the case of Periods 1 and 3, extra days (2 and 8, respectively) were collected to provide

an increased sample size of intervals to better calculate the meal criterion. The scanning interval employed by the GrowSafe system results in a high frequency of hit intervals at 6 s and multiples of 6. On a \log_{10} scale these were most evident at 6, 12, and 18 s and these intervals distorted the frequency distribution in such a way that it could not be modeled statistically. Therefore, hit intervals less than $1.3 \log_{10} s$ (~ 19 s) were removed prior to analysis. Meal criteria were calculated by fitting a mixture of two normal distributions to the distributions of \log_{10} -transformed hit intervals. The software package MIX 3.1.3 (Macdonald and Green, 1988) was used to fit these mixture distributions using the method of exact maximum likelihood. This method used the mixed probability density function:

$$g(x|p, \mu, s) = p_1 f(x|\mu_1, s_1) + \dots + p_k f(x|\mu_k, s_k)$$

where g is a weighted sum of k component densities. In the present study, $k = 2$, represented the two distributions of intervals: those within meal and those between meals. When fitting the distribution, the population of inter-meal intervals (left-hand distribution) was left truncated due to the removal of the intervals less than $1.3 \log_{10} s$. The meal criterion was determined as the point where the distribution curve of inter-meal intervals intersected the distribution curve of the intra-meal intervals. Individual meal criteria were calculated for each cow for each time period and a pooled criterion was calculated using the intervals from all cows for all time periods. The calculated meal criteria were used to calculate meal frequency (meals/d), simply by counting the number of intervals that exceeded the criterion and adding one. Meal duration (min/meal) was calculated as the time from the first hit until, but not including, a hit interval that exceeded the criterion. Total daily meal time (min/d) was simply the sum of these meal durations. These measures were calculated using the GrowSafe feed bunk monitoring software. In addition to these derived measures based on the meal criterion, we also recorded the number of hits (feeding

activity). For example, if a cow were at the feed bunk continuously for 6 h, 3600 (21,600 seconds/6 seconds hit⁻¹) hits would be recorded. Feeding intensity was calculated by dividing the number of hits/d by the total daily meal time.

2.2.4 Statistical Analyses

The individual animal was considered the observational unit in all analyses. Due to technical difficulty with the GrowSafe equipment, data were not collected for d 6 of Period 1. After a vast number of iterations, the MIX software was unable to fit the individual interval distribution for 2 cows in Period 3, resulting in no meal criterion for these animals for this period. The feeding behavior measures collected or calculated for the entire period (e.g. for meal frequency, total daily meal time, meal duration, feeding activity, and feeding intensity) were averaged to generate period means for each cow. All data were analyzed using the regression procedure of SAS (1985). To determine how the derived measures of behavior (i.e. meal frequency, etc.) were affected by the use of different estimates of the meal criterion, measures based on the individual criteria were regressed within cow onto those based on the pooled criterion, testing for slope and intercept effects. Linear regression was also used to determine the within cow repeatability of the repeated measures of feeding behavior. The data for each of the measures were regressed from Period 1 to Period 2 and from Period 2 to Period 3. To determine if cows changed their feeding behavior from one period to the next, the regression estimates of slope and intercept for the relationships of the individual behavioral measures for Periods 1 and 2 and for Periods 2 and 3 were tested. For all regression analyses, the intercept was tested for difference from zero, to determine if cows changed on average, and the slope was tested for difference from one, to determine the extent of the change relative to the initial value.

2.3 RESULTS

2.3.1 Meal Criteria

Meal criteria were calculated separately for each cow for each time period. The values varied among cows ranging from 8.4 min to 52.7 min; moreover, meal criteria varied among periods ranging from 30.8 ± 8.9 (mean \pm SD) min in Period 1 to 26.4 ± 9.4 (mean \pm SD) min in Period 3.

The use of the pooled criterion (27.7 min) versus the individual meal criteria resulted in very similar estimates of meal frequency and total daily meal time. The relationships between pooled and individual estimates for Period 1 are illustrated in Figure 2.1. The line equations and coefficients of determination were also calculated for Periods 2 and 3 for meal duration ($y = 1.09x - 34.89$, $R^2 = 0.95$; and $y = 0.94x + 23.66$, $R^2 = 0.86$, respectively) and for meal frequency ($y = 0.75x + 2.02$, $R^2 = 0.39$; and $y = 0.96x + 0.31$, $R^2 = 0.77$, respectively). In every case the coefficient was significant ($P < 0.01$). In addition, the intercept did not differ from zero and the slope did not differ from one ($P > 0.1$). Furthermore, all analyses reported below were completed using both an individual criterion and a pooled criterion and the results were similar from both approaches. We therefore used the pooled meal criterion (Figure 2.2) in all subsequent analyses. Using this criterion, we found an average meal frequency of 7.3 ± 1.5 (mean \pm SD) meals/d, meal duration of 47.1 ± 13.0 min/meal, and total daily meal time of 332.3 ± 69.2 min/d.

2.3.2 Repeatability of Feeding Behavior Measures

Linear regression was used to determine the within cow repeatability of the different measures of feeding behavior. For each variable, and for comparisons of both Period 1 to Period 2 and Period 2 to Period 3, coefficients of determination were significant ($P < 0.05$), but the

extent of repeatability varied considerably depending upon the measure of feeding behavior (Table 2.1). The within cow repeatability was highest for feeding activity and feeding intensity. For example, the high degree of consistency in feeding activity is shown in Figure 2.3. Other measures, like total daily meal time (Figure 2.4) showed only moderate repeatability across time periods, and repeated measures of meal frequency were only marginally related.

2.3.3 Changes in Feeding Behavior from Early to Peak Lactation

Cows changed aspects of their feeding behavior between Period 1 and Period 2 (Table 2.2), and again between Period 2 and Period 3 (Table 2.3). Regressions between the first two periods showed intercepts significantly higher than zero for total daily meal time, meal frequency, and meal duration, indicating general increases in these behaviors across cows. Additionally, cows with lower meal frequencies and feeding intensities during Period 1 showed greater increases during Period 2, compared to those cows having higher meal frequencies and feeding intensities during Period 1, as indicated by the slopes for these line equations being significantly less than one.

Cows showed different changes in feeding behavior across Periods 2 and 3. In particular, we found that cows with high feeding activity (hits/d) and feeding intensity (hits/meal min) in Period 2 showed proportionally greater increases during Period 3 as indicated by slopes significantly higher than one for these measures. In contrast, for total daily meal time and meal frequency, intercepts tended to be above zero and slopes less than one. This was attributed to cows with high values during Period 2 showing reduced durations and frequencies during Period 3, and cows with low values during Period 2 showing increased values during Period 3.

2.4 DISCUSSION

2.4.1 Meal Criteria

The literature has lacked a cohesive definition of meal criterion (Grant and Albright 1995). For example, using a subjective assessment of meals and visual observations, Sowell et al. (1999) defined the meal criterion as 5 min for beef feedlot cattle. Gibb et al. (1998) defined meal criterion as 20 min for beef feedlot cattle, but did not specifically state how this value was determined. In the current study, the use of the frequency distributions shows a first peak corresponding to intervals within meals and the second peak representing the intervals between meals. This distribution thus provides an objective and biologically relevant basis for identifying meal criterion; namely the interval where the two distributions intersect (Tolkamp et al., 1998). This meal criterion, calculated on an individual animal basis or on a group basis, is then used to determine the derived measures of feeding behavior. The present results showed that although individual cows differed to some degree in their meal criterion, using a pooled criterion (27.7 min) across cows and periods had little effect on the between time period analysis of the feeding behavior measures. Thus, although using a pooled criterion will result in some loss of detail, for some studies at least this pooled estimate will be adequate. However, in some cases where there is considerable variation in criteria (e.g., between cows or time periods), or when there are specific predictions concerning the treatment response of the criterion based measures it would be recommended to use individual criteria.

Tolkamp et al. (1998), Tolkamp and Kyriazakis (1999), and Yeates et al. (2001), using a data set collected from animals trained to feed from predetermined feeding stations, also reported a bi-modal frequency distribution of log-transformed intervals. These authors calculated meal

criteria ranging from 26.4 to 63.7 min, which was similar to the 8.4 to 52.5 min range found in the current study.

Tolkamp et al. (2000) reported that lactating dairy cows from early to mid lactation had an average meal criterion of 44.7 min, consumed 6.1 meals/d, and had a meal duration of 36.9 min/meal resulting in a total daily meal time of 225.1 min/d. These researchers used the same method described in the current study for estimating meal criterion, and the cows they used were similar in production levels and DMI to the cows used in our study. The longer meal criterion used by Tolkamp et al. (2000) translated into a lower meal frequency, but did not increase the meal duration or total daily meal time to the same levels as in the present study. This difference may indicate that the cows in our study had more non-feeding within meal intervals, perhaps due to increased disruption by other cows in our system compared to the electronic feeding gates and pre-assigned feeding stations used by Tolkamp et al. (2000).

The effect of reduced social interactions at the feeder may also explain differences between values obtained in our study and those from studies where cows were kept in tie stalls. Vasilatos and Wangsness (1980) found that early to peak lactation cows housed in a tie-stall barn consumed 12.1 meals/d at 20.9 min/meal, for a total daily meal time of 253 min/d. These values are considerably different from those obtained in all three time periods in the present study. In another study, Dado and Allen (1995) found that early lactation cows housed in tie stalls, with similar milk production and diet to the cows used in the present study, consumed 11.9 meals/d at 25.9 min/meal, for a total daily meal time of 294 min/d. Even though the value for total daily meal time is close to that found in the present study, the values for meal frequency and duration are quite different. It can be theorized that with less social disruption in tie stalls, we would expect fewer within meal disruptions, translating into more frequent, shorter meals, as seen in

both of these previous studies. Additionally, the meal criteria used in these studies were not defined in the same way as the present study, which may account for some of the variability between the results.

2.4.2 Repeatability of Feeding Behavior Measures

Measurements typically used to describe feeding behavior include meal frequency and duration (Senn et al., 1995; Nielsen, 1999). Researchers (Vasilatos and Wangsness, 1980; Dado and Allen, 1994; Nielsen, 1999) have tried to examine the relationships between feeding behavior variables, but to our knowledge no previous work has attempted to measure the repeatability of any measure of feeding behavior in dairy cattle. In the current study we used a sensitive within cow test and found that all measures were significantly related between time periods. We also found that the non-derived measures (e.g. hit frequency) showed far superior repeatability than the derived measures (e.g. meal frequency). Thus, even though cows organize their feeding bouts into meals, measures based on meals (e.g. meal frequency and duration) tend to be variable, and will likely prove to be relatively insensitive as measures to assess treatment differences. Since the highest within cow repeatability was seen in the feeding activity and intensity measures, we recommend that researchers use these measures in the future to assess treatment effects on feeding behavior, except when researchers have specific predictions concerning the treatment response of the criterion based measures.

2.4.3 Changes in Feeding Behavior from Early to Peak Lactation

There was substantial between-cow variation for all measures of feeding behavior for all three time periods. Examples of this can be seen in Figures 2.3 and 2.4 for the measures of

feeding activity and total daily meal time. This high between-cow variability indicates that relatively little can be learned from comparing the absolute values of these measures in different studies, or even the values from different cows within a study. Thus, we used within-cow regression analysis to compare time periods.

Previous research on feeding behavior of dairy cows has typically not considered the effects of differences in stage of lactation. In this present experiment, we measured the feeding behavior of the same group of cows at three different time periods from early to peak lactation. The relationships between the individual behavioral measures for Periods 1 and 2 (Table 2.2) and for Periods 2 and 3 (Table 2.3) indicated several changes in dairy cattle feeding behavior from early to peak lactation. The total daily meal time was increased from Period 1 to Period 2. This was not surprising since DMI has been shown to be continually increasing from the beginning of lactation to approximately 9 weeks into lactation (Kertz et al., 1991). The results from the comparison between Periods 2 and 3 indicated there was no overall increase or decrease in total daily meal time. Rather, it appears that the animals stabilized their feeding behavior between Period 2 and 3. In terms of meal frequency, there was a proportional increase in the number of meals per d, with the cows that had fewer meals per day during Period 1 having the greatest increase. Again, meal frequency was relatively stable between Periods 2 and 3. The increased total daily meal time and meal frequency from Period 1 to 2 also translated into an increase in meal duration, and this measure also remained stable between Periods 2 and 3. Friggens et al. (1998) studied the effects of stage of lactation on the short-term feeding behavior of dairy cows. These authors found no significant effect of stage of lactation for any of the behavior measures (visits to feed bin, duration of the visit, and food intake per visit). They also reported that even though DMI dropped in the later stages of lactation, there was no associated change in feeding

behavior. The difference between these findings and those from the current study may have been due to different measures of feeding behavior and no definition of meal criterion (Friggens et al., 1998).

In addition to the changes over time in the behavioral measures calculated with a meal criterion, changes were also detected in the measures derived from the hits produced by the GrowSafe system. The feeding activity of the cows remained unchanged from Period 1 to Period 2; however, from Period 2 to 3 there was a proportional increase (40% per cow) in feeding activity. The change in total daily meal time from Period 1 to 2 associated with no change in feeding activity, resulted in cows proportionally reducing their feeding intensity during Period 2. This indicates that even though they were spending more time in activities associated with eating, they were not spending any more time consuming feed at the feed bunk. The increase in feeding activity from Period 2 to Period 3 associated with no change in total daily meal time translated into a proportional increase (67%) in feeding intensity in Period 3. These increases in feeding activity and intensity indicate that during this peak production period, cows were spending more of their meal time actually at the feed bunk and reducing the intra-meal intervals away from the bunk.

2.5 CONCLUSIONS

The use of the \log_{10} -normal model described by Tolkamp et al. (1998) allows for the identification of a biologically relevant meal criterion for studying the feeding behavior of lactating dairy cows in early to peak lactation with unrestricted access to the feed bunk. This criterion provides an objective basis for calculations of meal frequency, meal duration, and total daily meal time and we recommend that this technique be employed in future research on feeding

behavior. Also, the measures of feeding activity and intensity obtained using the electronic feed bunk monitoring system can provide more repeatable and potentially more sensitive measures of responses to treatments that affect feeding behavior. The high amount of between-cow variability for all measures necessitates the use of within-cow tests when testing for changes in feeding behavior. In addition to this, studies of treatment effects on feeding behavior should control for days in milk.

2.6 ACKNOWLEDGEMENTS

We thank the staff and students at The University of British Columbia's Dairy Education and Research Centre and the University's Animal Welfare Program. We also thank Dr. Peter Macdonald from McMaster University for his help with the mixture distribution analysis. Trevor DeVries was supported by a Natural Sciences and Engineering Research Council of Canada Postgraduate Scholarship. The project was funded by the Natural Sciences and Engineering Research Council of Canada, through the Industrial Research Chair in Animal Welfare, and by contributions from the Dairy Farmers of Canada, the Beef Cattle Industry Development Fund, the BC Dairy Foundation, the BC SPCA, members of the BC Veterinary Medical Association, and many other donors listed on our website at <http://www.landfood.ubc.ca/animalwelfare>.

Table 2.1. Regression coefficients for the relationship between time periods for different measures of feeding behavior. All relationships are significant at $P < 0.05$.

Measure	Period 1 ¹ vs. Period 2 ²	Period 2 vs. Period 3 ³
Feeding activity ⁴	0.91	0.90
Feeding intensity ⁵	0.85	0.91
Total daily meal time ⁶ (min/d)	0.72	0.75
Meal duration (min/meal)	0.55	0.50
Meal frequency (meals/d)	0.34	0.22

^{1,2,3}Data for each variable were calculated for 21 cows averaged for three 8-d time periods where cows were on average 35, 57, and 94 DIM, respectively.

⁴The total number of data points that the feed bunk monitoring system recorded per day.

⁵The number of hits/d divided by the total daily meal time.

⁶Sum total length of time (min) included in the meals/day.

Table 2.2. Intercepts and slopes of line equations from the regression of feeding behavior measures in Period 1¹ versus Period 2². *P*-values are from tests of the hypotheses that the intercept = 0 and slope = 1.

Measure	Intercept ± SE	<i>P</i>	Slope ± SE	<i>P</i>
Feeding activity ³	78.54 ± 69.73	0.27	0.92 ± 0.06	0.22
Feeding intensity ⁴	0.34 ± 0.25	0.20	0.73 ± 0.07	0.001
Total daily meal time ⁵ (min/d)	114.23 ± 34.27	0.004	0.80 ± 0.11	0.10
Meal duration (min/meal)	19.86 ± 6.08	0.004	0.71 ± 0.15	0.07
Meal frequency (meals/d)	3.84 ± 1.15	0.004	0.48 ± 0.15	0.003

^{1,2}Data for each variable were calculated for 21 cows averaged for two 8-d time periods where cows were on average 35 and 57 DIM, respectively.

³The total number of data points that the feed bunk monitoring system recorded per day.

⁴The number of hits/d divided by the total daily meal time.

⁵Sum total length of time (min) included in the meals/day.

Table 2.3. Intercepts and slopes of line equations from the regression of feeding behavior measures in Period 2¹ versus Period 3². *P*-values are from tests of the hypotheses that the intercept = 0 and slope = 1.

Measure	Intercept ± SE	<i>P</i>	Slope ± SE	<i>P</i>
Feeding activity ³	67.24 ± 112.38	0.56	1.40 ± 0.11	0.001
Feeding intensity ⁴	-0.50 ± 0.35	0.17	1.67 ± 0.12	0.001
Total daily meal time ⁵ (min/d)	68.18 ± 37.17	0.08	0.79 ± 0.11	0.06
Meal duration (min/meal)	8.07 ± 9.96	0.43	0.89 ± 0.20	0.58
Meal frequency (meals/d)	3.04 ± 1.70	0.09	0.53 ± 0.23	0.05

^{1,2}Data for each variable were calculated for 21 cows averaged for two 8-d time periods where cows were on average 57 and 94 DIM, respectively.

³The total number of data points that the feed bunk monitoring system recorded per day.

⁴The number of hits/d divided by the total daily meal time.

⁵Sum total length of time (min) included in the meals/day.

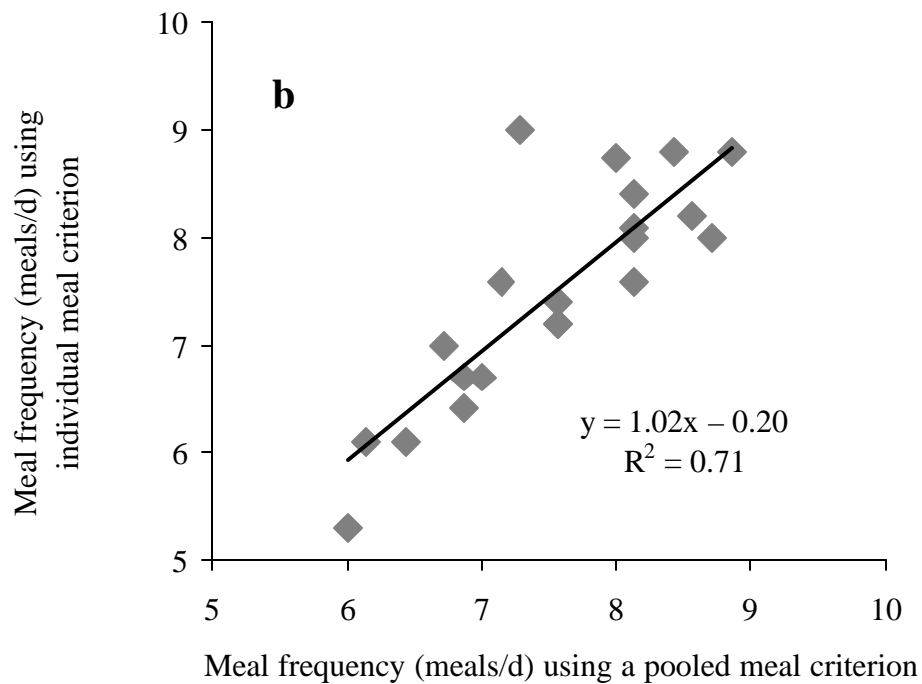
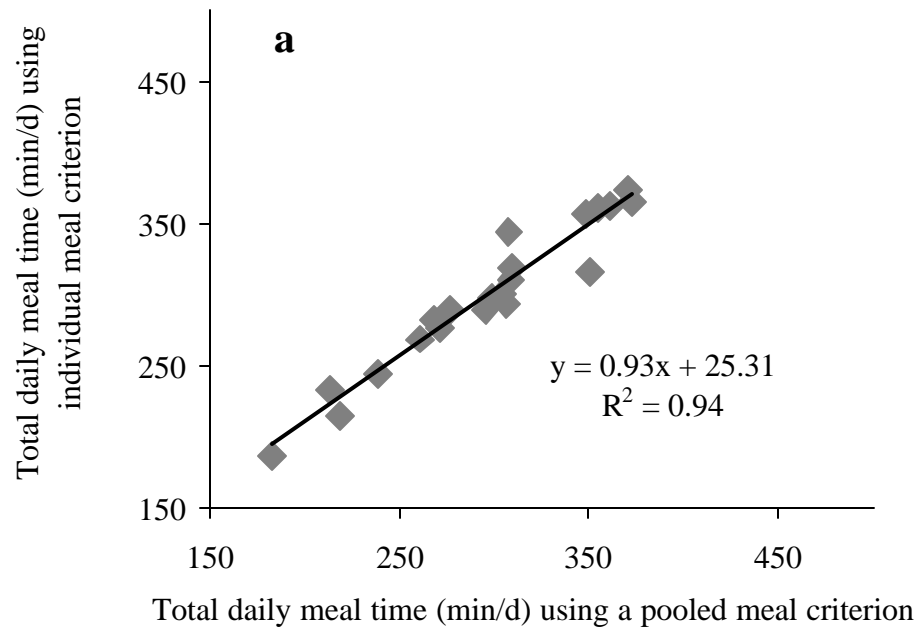

Figure 2.1. The relationship of (a) total daily meal time (min/d) and (b) meal frequency (meals/d) calculated with a pooled meal criterion (27.7 min) and with individual meal criterion. Meal frequency and total daily meal time were calculated for 21 cows averaged for 8 d starting at an average 35 DIM.

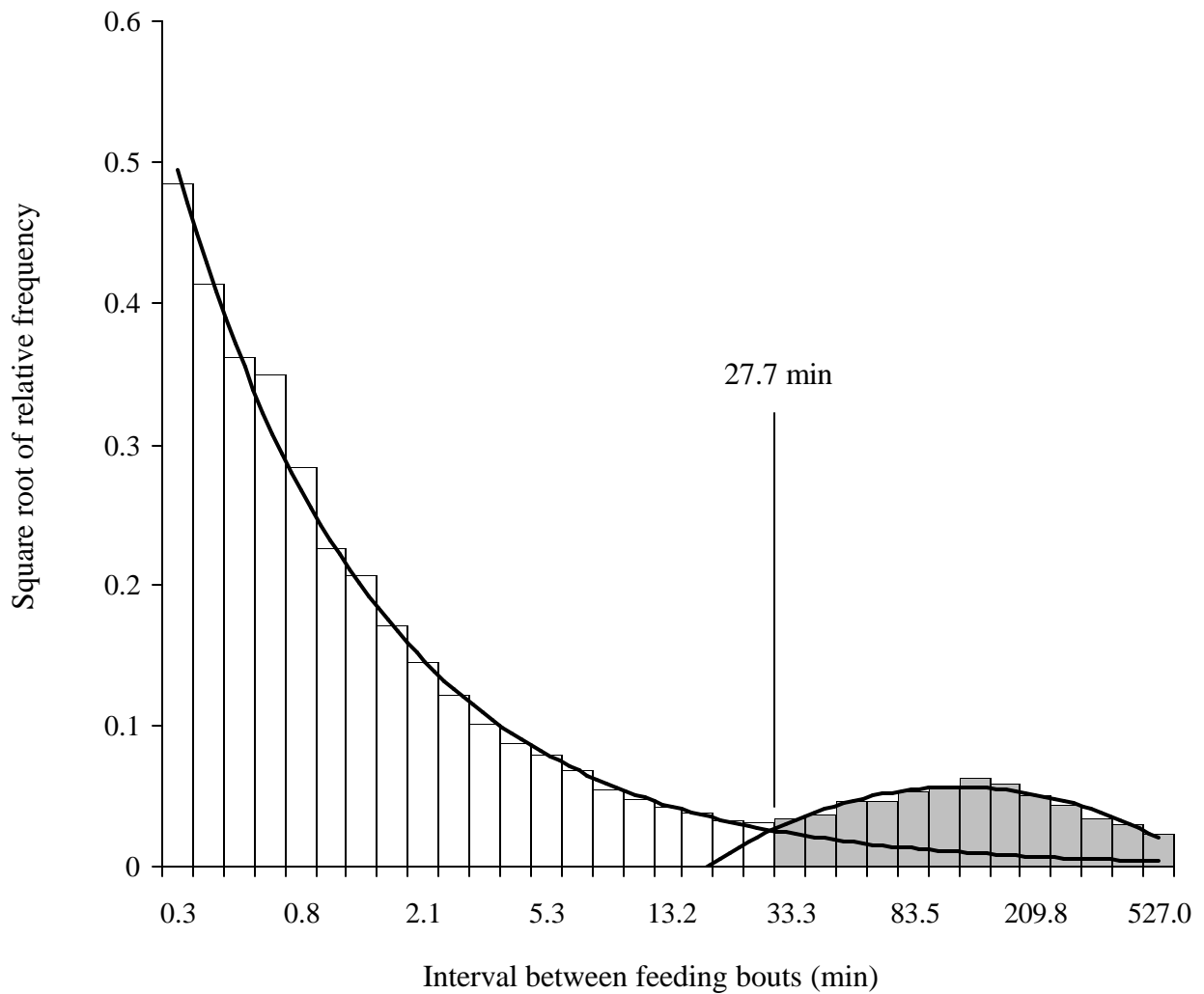

Figure 2.2. Square-root transformed relative frequency distribution of the intervals ($n = 180,676$) between the electronic feed bunk monitoring system data points fitted with a mixed distribution model. Data presented is summarized for 21 cows for the data collected for the three time periods: 10 d starting at average 35 DIM, 8 d starting at average 57 DIM, and 16 d starting at average 94 DIM. Square-root transformation is used here to better illustrate the two distributions and was not used in the mixture analysis of the distributions.

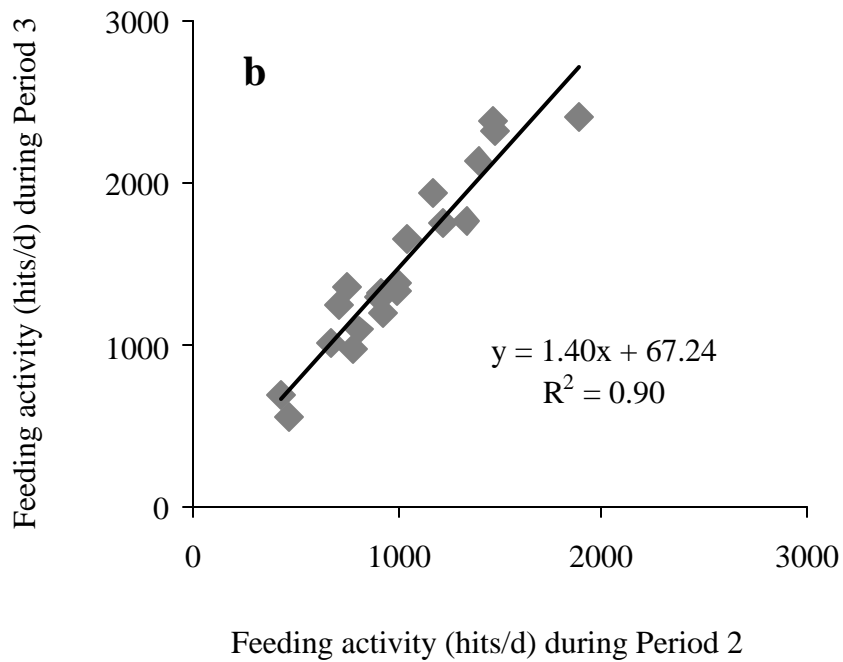
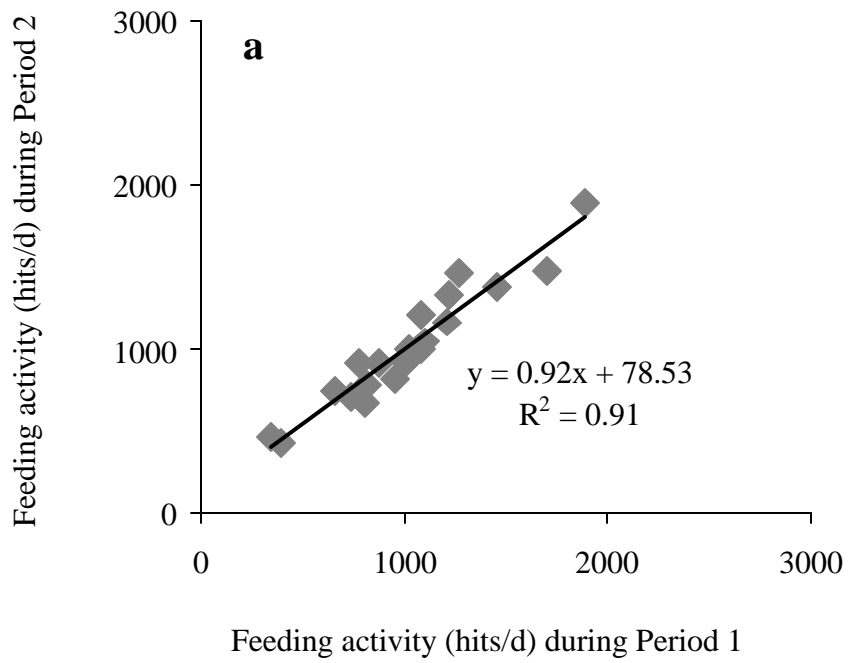

Figure 2.3. The relationship between the average feeding activity (hits/d) of 21 cows for (a) Period 1 and 2 and (b) Period 2 and 3. Periods 1, 2, and 3 represent 8-d periods starting at an average of 35, 57, and 94 DIM, respectively.

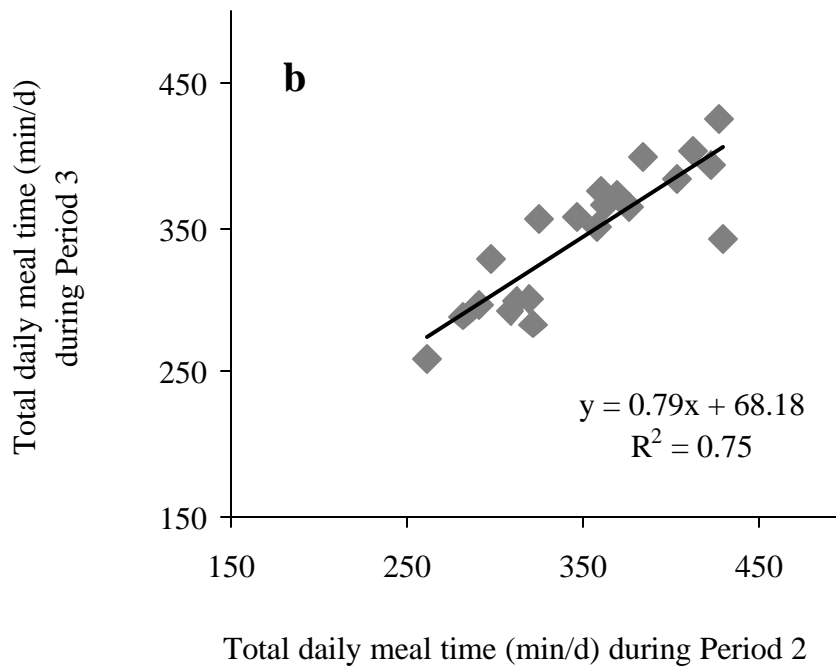
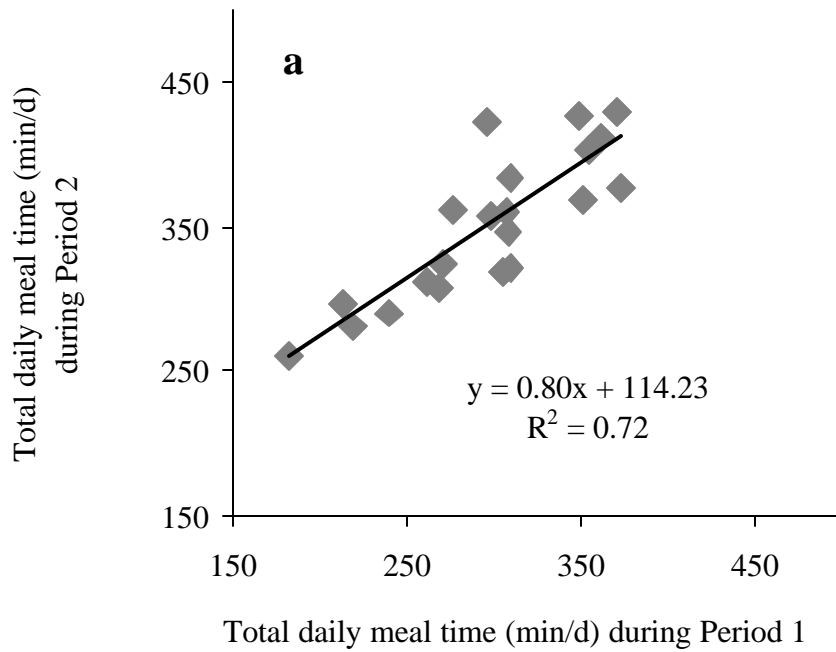

Figure 2.4. The relationship between the average total daily meal time (min/d) of 21 cows for (a) Period 1 and 2 and (b) Period 2 and 3. Periods 1, 2, and 3 represent 8-d periods starting at an average of 35, 57, and 94 DIM, respectively.

2.7 REFERENCES

- Canadian Council on Animal Care. 1993. Guide to the care and use of experimental animals. Vol. 1. E. D. Olfert, B. M. Cross, and A. A. McWilliam, ed. CCAC, Ottawa, ON, Canada.
- Dado, R. G., and M. S. Allen. 1994. Variation in and relationships among feeding, chewing, and drinking variables for lactating dairy cows. *J. Dairy Sci.* 77:132-144.
- Dado, R. G., and M. S. Allen. 1995. Intake limitations, feeding behavior, and rumen function of cows challenged with rumen fill from dietary fiber or inert bulk. *J. Dairy Sci.* 78:118-133.
- Forbes, J. M. 1995. *Voluntary Food Intake and Diet Selection in Farm Animals*. CAB Int., Wallingford, United Kingdom.
- Friggens, N. C., B.L. Nielsen, I. Kyriazakis, B. Tolcamp, and G. C. Emmans. 1998. Effects of food composition and stage of lactation on the short-term feeding behavior of dairy cows. *J. Dairy Sci.* 81:3268-3277.
- Gibb, D. J., T. A. McAllister, C. Huisma, and R. D. Wiedmeirer. 1998. Bunk attendance of feedlot cattle monitored with radio frequency technology. *Can. J. Anim. Sci.* 78:707-710.
- Grant, R. J., and J. L. Albright. 1995. Feeding behavior and management factors during the transition period in dairy cattle. *J. Anim. Sci.* 73:2791-2803.
- Grant, R. J., and J. L. Albright. 2000. Feeding Behaviour. Pages 365-382 *in Farm Animal Metabolism and Nutrition*. J. P. F. D'Mello, ed. CABI Publishing, Wallingford, Oxon, UK.
- Kertz, A. F., L. F. Reutzel, and G. M. Thomson. 1991. Dry matter intake from parturition to midlactation. *J. Dairy Sci.* 74:2290-2295.
- Langton, S. D., D. Collett, and R. M. Sibly. 1995. Splitting behaviour into bouts: a maximum likelihood approach. *Behaviour*. 132: 781-799.
- Macdonald, P. D. M., and P. E. J. Green. 1988. User's Guide to Program MIX: an interactive program for fitting mixtures of distributions. Release 2.3, January 1988. Ichthus Data Systems, Hamilton, Ontario. iv+60 pp. ISBN 0-9692305-1-6.
- Menzi, Wm. Jr., and L. E. Chase. 1994. Feeding behavior of cows housed in free stall barns. Pages 829-833 *in Dairy Systems for the 21st Century*. American Society of Agricultural Engineers. St. Joseph, MI.
- National Research Council. 2001. Nutrient requirements of dairy cattle. 7th rev. ed. National Academy Press, Washington DC.
- Nielsen, B. L. 1999. On the interpretation of feeding behaviour measures and the use of feeding rate as an indicator of social restraint. *Appl. Anim. Behav.* 63:79-91.

SAS User's Guide: Statistics, Version 5 Edition. 1985. SAS Inst., Inc., Cary, NC.

Schwartzkopf-Genswein, K. S., C. Huisma. and T. A. McAllister. 1999. Validation of a radio frequency identification system for monitoring the feeding patterns of feedlot cattle. *Livestock Prod. Sci.* 60:27-31.

Senn, M., B. Durst, A. Kaufmann, and W. Langhans. 1995. Feeding patterns of lactating cows of three different breeds fed hay, corn silage, and grass silage. *Physiology and Behavior.* 58:229-236.

Sibly, R. M., H. M. R Nott, and D. J. Fletcher. 1990. Splitting behaviour into bouts. *Anim. Behav.* 39:63-69.

Slater, P. J. B., and N. P. Lester. 1982. Minimising errors in splitting behaviour into bouts. *Behaviour.* 79:153-161.

Sowell, B. F., J. P. G. Bowman, M. E. Branine, and M. E. Hubbert. 1998. Radio frequency technology to measure feeding behavior and health of feedlot steers. *Appl. Anim. Behav. Sci.* 59:277-284.

Sowell, B. F., M. E Branine, J. G. P. Bowman, M. E Hubbert, H. E. Sherwood, and W. Quimby. 1999. Feeding and watering behavior of healthy and morbid steers in a commercial feedlot. *J. Anim. Sci.* 77:1105-1112.

Tolkamp, B. J., D. J. Allcroft, E. J. Austin, B. L. Nielsen, and I. Kyriazakis. 1998. Satiety splits feeding behaviour into bouts. *J. Theor. Biol.* 194:235-250.

Tolkamp, B. J., and I. Kyriazakis. 1997. Measuring diet selection in dairy cows: effect of training on choice of dietary protein level. *Anim. Sci.* 64:197-207.

Tolkamp, B. J., and I. Kyriazakis. 1999. To split behaviour into bouts, log-transform the intervals. *Anim. Behav.* 57:807-817.

Tolkamp, B. J., D. P. N. Schweitzer, and I. Kyriazakis. 2000. The biologically relevant unit for the analysis of short-term feeding behavior of dairy cows. *J. Dairy Sci.* 83:2057-2068.

Vasilatos, R., and P. J. Wangsness. 1980. Feeding behavior of lactating dairy cows as measured by time-lapse photography. *J. Dairy Sci.* 63:412-416.

Yeates, M. P., B. J. Tolkamp, D. J. Allcroft, and I. Kyriazakis. 2001. The use of mixed distribution models to determine bout criteria for analysis of animal behaviour. *J. Theor. Biol.* 213:413-425.

CHAPTER 3: Time of feed delivery affects the feeding and lying patterns of dairy cows^{2?}

3.1 INTRODUCTION

Grazing cattle typically display a diurnal feeding pattern, consuming the majority of their daily intake during the daytime (Hafez and Bouissou, 1975). Intensively housed dairy cattle have been reported to exhibit similar patterns. Haley et al. (2000) showed that individually housed cows in tie stalls tended to eat the majority of their food during the day, with peak feeding activity occurring immediately following milking and feeding. Similar responses to milking and feeding have also been demonstrated for cows in free stall housing (e.g. Tanida et al., 1984; DeVries et al., 2003a; Wagner-Storch and Palmer, 2003).

On many commercial dairy farms, fresh feed is delivered to the pen while cows are away for milking. The presence of fresh feed when cows return from milking is thought to stimulate cows to feed rather than to lie down, thereby potentially reducing the risk of mastitis by providing more time for the teat canals to close before they contact the stall surface (Tyler et al., 1997; Johansson et al., 1999). Unfortunately, little is known about what factors actually stimulate cows to move to the feed bunk. Moreover, there is also limited work on the effect of providing fresh feed upon return from milking on latency to lie down after milking. Thus, the objective of this experiment was to evaluate the effect of when fresh feed is delivered relative to milking on the feeding and lying behavior of lactating dairy cows.

3.2 MATERIALS AND METHODS

3.2.1 Animals, Housing, and Diet

²A version of this chapter has been published. DeVries, T. J. and M. A. G. von Keyserlingk. 2005. Time of feed delivery affects the feeding and lying patterns of dairy cows. *J. Dairy Sci.* 88:625-631.

Nineteen primiparous and 29 multiparous (parity = 2.9 ± 0.8 ; mean \pm SD) lactating Holstein dairy cows were used in the study. The animals were 108.5 ± 17.9 DIM at the beginning of the data collection period. The cows were housed in a free-stall barn located at The University of British Columbia Dairy Education and Research Centre (Agassiz, BC, Canada) and were managed according to the guidelines set by the Canadian Council on Animal Care (1993). The cows were fed ad libitum a TMR consisting of 17% corn silage, 17% grass silage, 7% alfalfa hay, 9% 4th cut grass hay, 15% energy blend, and 35% concentrate mash on a DM basis. The composition of the TMR was 51% DM and contained on a DM basis 18% CP, 32% NDF, 19% ADF, and 1.0% Ca, and 0.5% P. The TMR was formulated according to the NRC (2001) nutrient requirement recommendations for high producing dairy cows. Cows consumed their feed from a feed bunk with access via a pendulous feed rail and had 0.55 m of feeding space per animal. In addition, each cow had access to a free stall that was deep bedded with sand. The animals were milked between 0500 and 0530 h in the morning and between 1700 and 1730 h in the afternoon. The animals were milked in a double-12 parallel milking parlor and were moved to and from the parlor together in their respective groups. Milk yields were automatically recorded at each milking.

Samples of the TMR were taken at each feeding and from the feed refusals each day of the experiment. Dry matter of the samples was determined by drying in a hot air oven at 60 °C for 3 d. The DMI for each group for each day on treatment were recorded by subtracting the DM weight of the orts from the DM weight of the fresh feed. The daily orts averaged 7.5 ± 4.4 (mean \pm SD) % of the fresh feed provided over the course of the experiment.

3.2.2 Experimental Treatments and Design

The 48 lactating cows were used in a 2 x 2 cross-over design replicated over time. The animals were divided into 4 equal groups of 12 cows, which were balanced according to projected 305 d milk production ($10,610.4 \pm 1859.9$ kg; mean \pm SD), average DIM (108.5 ± 17.9), and average parity (2.2 ± 1.1). Each group was subjected to each of 2 treatments. The treatments were: 1) milking and feed delivery times coinciding and 2) delivery of feed 6 h after milking. Feed refusals were removed immediately prior to the delivery of fresh feed for each day for both treatments, at 0515 h and 1115 h respectively. Feed push-up occurred twice daily: 6 h after feeding for each group. Feeding and pushing up feed at 6-h intervals ensured that feed was available to the cows for all hours in the day in which they were in their respective pens.

All groups were housed together for 1 wk prior to the experimental phase to allow for social adaptation. Initially, the 2 treatments were applied to the first 2 groups of cows for a 3-d adjustment period followed by 7 d of data collection. After this was completed, the treatments were switched between the groups. Again, animals were given a 3-d adjustment period followed by 7 d of observations on the new treatment. This same procedure was then repeated with the 2 remaining groups of cows.

3.2.3 Behavioral Recording

The lying and feeding behavior, and number of aggressive interactions for all cows were recorded for 7 d per treatment. Lying and aggressive behavior were monitored using time-lapse video equipment. The animals were videotaped using 2 video cameras (Panasonic WV-BP330; Osaka, Japan) per pen, a time-lapse videocassette recorder (Panasonic AG-6540) and a video multiplexer (Panasonic WJ-FS 216). For each pen, a video camera was located 6 m above the feed bunk and another camera was located 10 m above the free stalls. Red lights (100 W), hung

adjacent to the cameras, were used to facilitate recording at night. Individual animals were identified with unique alphanumeric symbols made with hair dye (Clairol's Nice and Easy # 122, Natural Black, or Clairol's L'image Maxiblonde, depending on hair color; Stamford, CT) on their backs. Feeding behavior was monitored for the entire experiment using an electronic feed bunk monitoring system (GrowSafe Systems Ltd., Airdrie, AB, Canada) that recorded individual cow presence (hits: a reading that occurs every 6 s for the duration of time the cows is feeding) at the feed bunk. This system has previously been described (DeVries et al., 2003b) and validated (see Appendix 1: DeVries et al., 2003c).

3.2.3.1 Measuring feeding behavior. The feeding behavior of individual cows was quantified using measures of feeding time, as this has previously been described as the most repeatable and sensitive measure of feeding behavior (DeVries et al., 2003b). Since the scanning interval of the electronic monitoring system was 6 s, we were able to convert the number of hits into feeding time (i.e. number of hits \times 6 s/60 s min⁻¹ = min feeding time). Total daily feeding time was calculated for each cow for each treatment day. Feeding time was also calculated for the 60-min period following the return of the last cow from milking (appearance of the last cow to enter the pen after milking marked the beginning of this period) and following the provision of fresh feed (when delivered at 1130 h and 2330 h). These 60-min periods were identified in this study and in a previous study (DeVries et al., 2003a) as the times when the largest concentrations of cows are present at the feed bunk.

3.2.3.2 Measuring lying behavior. Daily lying times were obtained from the video recordings, using instantaneous scan sampling once every 10 min (Fregonesi et al., 2004). In addition, we monitored the length of time it took cows to lie down upon return from the milking parlor (i.e. latency to lie down). This was quantified by continuously watching the video

recordings from the time the cows returned from the parlor until they lay down in one of the stalls.

3.2.3.3 Measuring aggressive behavior. Aggressive displacements at the feed bunk were recorded during the 60-min period following the return from milking and following the provision of fresh feed (when delivered at 1130 h and 2330 h). A displacement was noted when a butt or a push from the actor (instigator) resulted in the complete withdrawal of the reactor's head from beneath the feed rail (DeVries et al., 2004).

3.2.4 Data Analyses

For the analyses of feeding behavior, DMI, milk yield, lying behavior, and displacements from the feed bunk, the pen was considered as the experimental unit, with measures from multiple days and cows averaged to create one observation per pen per treatment. Treatment effects on the feeding behavior measures, DMI, milk yield, lying behavior measures, and number of displacements were tested by one-sample paired *t*-tests with 3 degrees of freedom.

Overall, treatment response was tested using the pen as the experimental unit. However, to determine if cows with higher feeding times were more affected by treatment we used a within-cow test. Feeding times (60 min after milking and feeding) during the two treatments were compared using the regression procedure of SAS (1985). A test of the intercept term (difference from zero) revealed the mean effect of treatment, and a test of the slope (difference from one) assessed if the response to treatment varied in relation to the initial value.

3.3 RESULTS

3.3.1 Feeding Behavior, Feed Intake, and Milk Yield

When animals were fed 6 h after milking they increased their total daily feeding time by 12.5% (Table 3.1). This change was predominantly driven by an 82% increase in feeding time during the 60 min following the delivery of fresh feed and a 26% decrease in feeding time during the 60 min after milking. Figure 3.1 illustrates the presence of fewer animals feeding during the time period immediately following the return from milking when no fresh feed was delivered at that time. Further, we noted a substantial increase in the number of animals feeding after the delivery of fresh feed at 1130 h and 2330 h compared to when they were fed at milking time.

Since there were significant changes in feeding time when cows were fed 6 h after milking, we used linear regression to determine how the individual cows responded to the treatment after they returned from milking (Figure 3.2a) and after they received fresh feed (Figure 3.2b). The coefficient of determination was statistically significant ($P < 0.001$) for both relationships, indicating that cows were relatively consistent in feeding times across treatments. For feeding time after milking, the intercept (2.40 ± 1.55 ; mean \pm SE) was not significantly greater than zero ($P = 0.13$), but the slope was less than one (0.58 ± 0.09 ; $P < 0.001$). For the feeding time after delivery of fresh feed, the intercept was greater than zero (12.53 ± 2.61 ; $P < 0.001$) and the slope was not different than one (1.00 ± 0.15 ; $P = 0.99$).

There was no difference in DMI when groups had fresh feed upon return from milking compared to when they were fed 6 h after milking (22.9 ± 0.4 kg versus 22.2 ± 0.4 kg/cow/d; $P = 0.3$). Additionally, there was no difference in milk yield when groups had fresh feed upon return from milking compared to when they were fed 6 h after milking (38.1 ± 0.6 kg versus 37.1 ± 0.6 kg/cow/d; $P = 0.3$).

3.3.2 Lying Behavior

Cows spent on average 12.3 h/d lying down, regardless of treatment (SE = 0.32, $P = 0.9$). However, the distribution of lying time throughout the day was affected by the timing of fresh feed delivery. Those cows that were fed 6 h after milking showed 4 peaks of lying activity compared to the 2 extended periods of lying activity observed for the cows provided fresh feed upon return from milking (Figure 3.3). Moreover, cows that did not have fresh feed upon return from milking showed an average latency to lie down of 45.1 min, versus 65.7 min for cows with access to fresh feed upon the return from milking (SE = 0.83, $P < 0.001$).

3.3.3 Aggressive Behavior at the Feed Bunk

During the 60 min after milking, cows physically displaced one another from the feed bunk at a frequency of 1.03 displacements per cow when provided access to fresh feed and 0.67 displacements per cow when fresh feed was provided later (SE = 0.11; $P = 0.1$). During the 60-min observational period after the delivery of fresh feed, we observed no significant difference in the frequency of displacements at the feed bunk when cows were fed at the time of milking compared to when they were fed 6 h after milking (1.03 versus 1.11 displacements/cow; SE = 0.11, $P = 0.5$).

3.4 DISCUSSION

Cows spent 26% more time feeding during the hour after the return from milking when provided access to fresh feed compared to when they did not have fresh feed upon the return from milking. However, providing fresh feed 6 h after milking increased feeding time by 82% during the hour after feed was delivered, such that daily feeding time was 12.5% greater when

cows were fed in this way. To our knowledge, this is the first published evidence that separating times of milking and delivery of fresh feed affects the pattern of feeding and increases total daily feeding time.

There was substantial variation among cows in their response to treatment. Cows that had the highest feeding time post-milking when fed at the time of milking had the greatest decreases in feeding time post milking when feed was delivered 6 h after milking. Alternatively, all cows showed a similar increase in feeding time during the first hour after feeding when fed 6 h post milking. This substantial increase in feeding time by all cows during the first hour after the 6 h delayed delivery of fresh feed indicates that the delivery of fresh feed is a much stronger stimulus to get cows to feed than does the return from the milking parlor.

It is also interesting to note that when the cows were fed 6 h after milking, they shifted their daily feeding pattern. Previously, dairy cows have been described as crepuscular feeders, being influenced by the timing of sunrise and sunset (e.g. Albright, 1993). However, the results of this study indicate that the daily feeding pattern of dairy cows kept indoors is more affected by the timing of fresh feed delivery than by the time of day.

Group feed intakes were used to calculate the average DMI per cow per treatment, and we found no effect of treatment on this measure. We also found no effect of treatment on the milk yield of the cows. However, this study was designed to test predictions concerning feeding behavior, and does not provide a strong test of intake or milk yield differences. The regression analysis on the measures of feeding behavior indicated that cows varied in their response to treatment, and this same variation may also have occurred in individual DMI. The effect of treatment on DMI and milk yield could be properly assessed in a future study using equipment

that accurately measures individual DMI and longer treatment periods to assess the effect of these treatments on milk yield.

Despite the increase in feeding time when cows were given fresh feed 6 h after milking, they did not change their total daily lying time. This result indicates that the increase came out of the time cows otherwise spent idle waiting for feed or for access to the feeding area. It must be noted, however, that cows did change their pattern of lying. The latency to lie down after milking decreased by 20 min when cows were provided fresh feed 6 h after milking compared to those that had access to fresh feed immediately after milking. Schultz (1985) found that when feed was scarce upon returning from the milking parlor considerably more cows were observed lying down within 15 min compared to when feed was abundant. Unfortunately, this author only reported percentage of cows lying at a specific time after milking and not the latency to lie. Tyler et al. (1997) found that cows, which had access to feed after milking stood on average for 48 min compared to cows which stood for only 21 min when they did not have access to feed. The fact that cows in the current study all had access to feed upon return from milking (even though it may have been delivered 6 h earlier), may explain why the latency to lie down was greater than that reported by Tyler et al. (1997). Johansson et al. (1999) found that the percentage of cows lying down immediately after milking was affected by the time of feeding. They compared feeding at 1.5 h prior to milking, at the same time as milking, and 1.5 h after milking and reported that the delivery of feed at milking caused a lower percentage of cows to lie down within the first hour after milking. In contrast, those cows fed 1.5 h after milking had the highest percentage lying within the first hour after milking. Unfortunately, comparison of our work with that study is difficult since the cows that were fed 1.5 h after milking did not have any food available when they returned from the parlor. As previously mentioned, the cows in our study

had feed available for all the time during the day in which they were in their respective pen. Also, Johansson et al. (1999) reported only the percentage of cows lying within a 1-h period and did not measure the latency to lie down.

The practical significance of management practices that affect latency to lie following milking is not fully understood. The common belief is that the longer the animal stands after milking, the lower the risk for bacterial penetration of the teats when the cow eventually lies down. McDonald (1975) measured the dilation of the teat at 0, 2, 4, 6, and 8 h after milking and found that the teat was most constricted at 2 h after milking. Schultze and Bright (1983) injected the teat of lactating dairy cows with a bacterial endotoxin at different time periods after milking and found high penetrability during the first 30 min. This penetrability was much reduced by 2 h after milking. Unfortunately, as with the study by McDonald (1975), no intermediate samples were taken, so it is difficult to assess the exact time within the first 120 min after milking when the teat is most constricted and the risk of penetrability by bacteria is lowest. In the present study, due to the restricted length of the treatment periods and the total number of animals, it was impossible to test for any treatment effect on the incidence of mastitis. This effect could be ascertained in a future study designed to test the effect of the length of latency to lie following milking on the incidence of mastitis.

In the present study, there was a tendency for cows to engage in fewer aggressive interactions at the feed bunk after the cows returned from milking when they did not have access to fresh feed. Johansson et al. (1999) found that tie-stall housed dairy cows, given no feed 1.5 h after milking, showed fewer social interactions during this period. They attributed this finding to the cows spending more time performing behaviors associated with food searching. In the free stall environment used in the present study, food-searching behavior by an individual cow will be

influenced by social interactions with other cows at the feed bunk. In our study, the failure to deliver fresh feed immediately after milking corresponded with a trend for fewer displacements after milking. This trend may have been the result of there being less feed available to fight over at this time and a reduction in the time spent searching for feed. As a result, these cows reduced their time spent at the feed bunk at this time, resulting in a decreased latency to lie down compared to those that had fresh feed delivered.

3.5 CONCLUSIONS

Shifting the time of feed delivery away from milking time increased daily feeding time and altered feeding and lying patterns. These results indicate that the delivery of fresh feed has a greater impact on stimulating cows to feed than does the return from milking. The results also indicate that the daily feeding pattern of group-housed dairy cows is largely influenced by the timing of fresh feed delivery.

3.6 ACKNOWLEDGEMENTS

We thank the staff and students at The University of British Columbia's Dairy Education and Research Centre and the University's Animal Welfare Program. In particular we thank Katie Martinolich for her help with running the experiment and with the video analysis. We also thank Agriculture and Agri-Food Canada's Lethbridge Research Centre for the use of their feeding behavior monitoring system. Trevor DeVries was supported by a Natural Sciences and Engineering Research Council of Canada (NSERC) Postgraduate Scholarship. The project was funded by the Agriculture and Agri-Food Canada/NSERC Research Partnership Support Program made possible by contributions from the Dairy Farmers of Canada.

Table 3.1. Total daily feeding time and for the 60-min period following the return from milking for both treatments and for the 60-min period following the delivery of fresh feed for when cows were fed 6 h post-milking¹. The least-square SE and *P* values for the test of treatment are provided.

	Treatment		SE	<i>P</i>
	Feed delivery and milking time coincide	Feed delivery 6 h after milking		
Daily (min/d) ²	191.9	215.9	3.41	0.016
Return from milking (min) ³	15.6	11.6	0.39	0.006
Delivery of fresh feed (min) ⁴	15.6	28.3	1.33	0.007

¹Data were averaged for 7 d per treatment for 4 groups of cows (12 cows per group).

²Average feeding time per cow per day.

³Average feeding time per cow during the 60 min following the return from the milking parlor.

⁴Average feeding time per cow during the 60 min following provision of fresh feed.

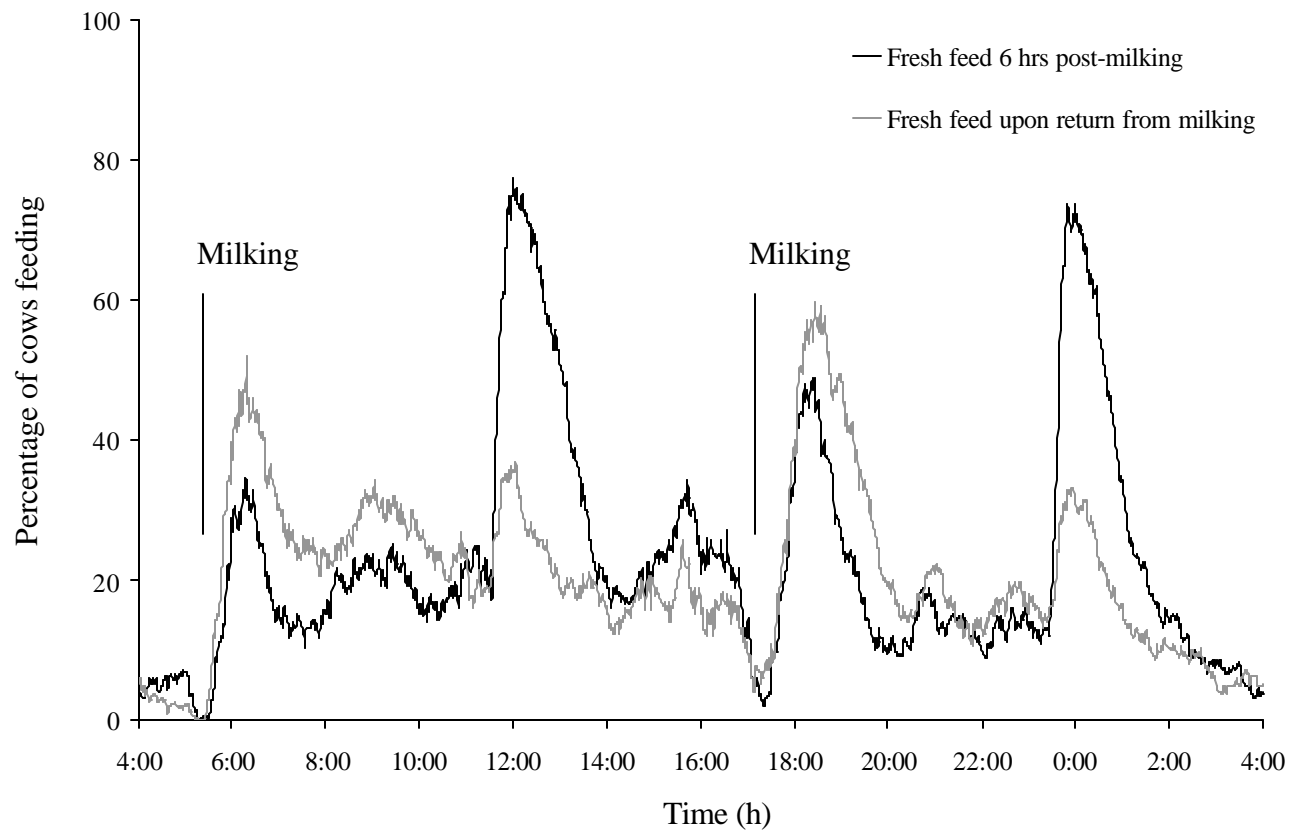

Figure 3.1. Percentage of cows per group present at the feed bunk over a 24-h period (percentage for each 60-s interval during the day) for 2 treatments: 1) cows were milked and fed at 0530 and 1730 h, and 2) cows were milked at 0530 and 1730 h and fed at 1130 h and 2130 h. Data were averaged for 7 d per treatment for 4 groups, each containing 12 cows. Data are presented from 0400 h, since this was a time of low feeding activity for both treatments.

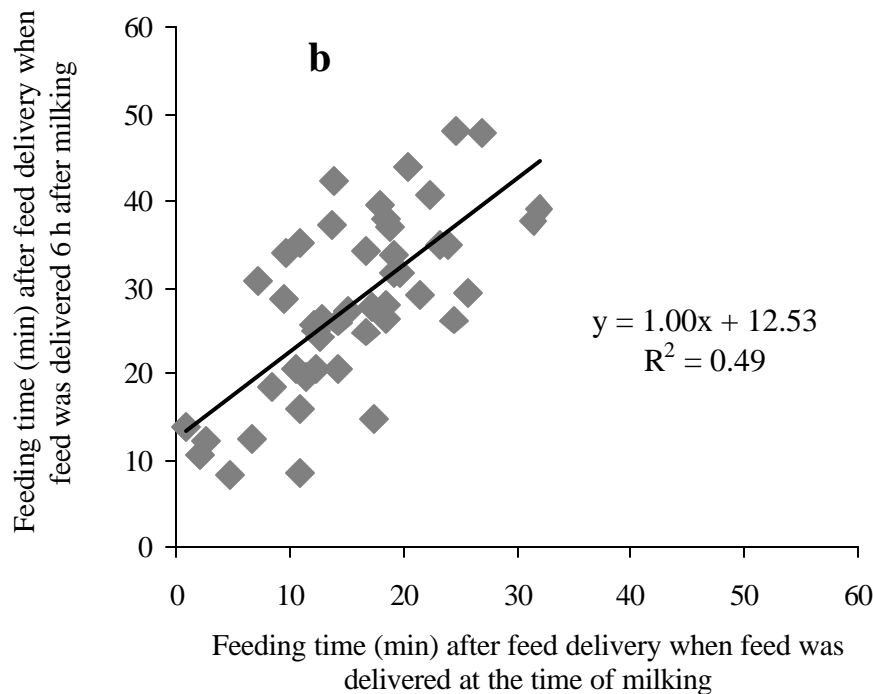
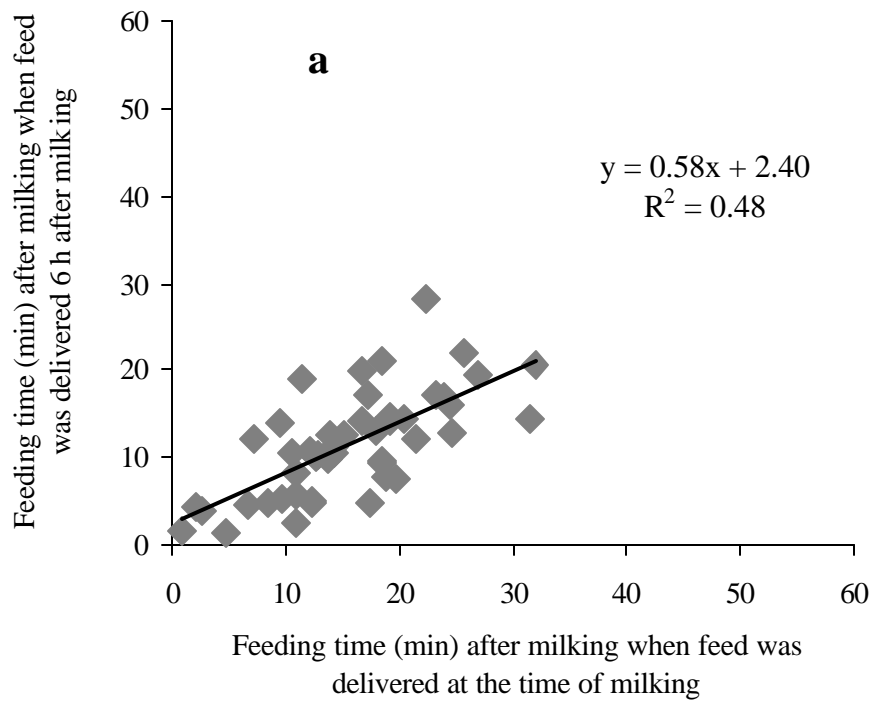

Figure 3.2. The relationship of feeding time (min) during the 60-min period following (a) the return from milking and (b) the delivery of fresh feed measured on dairy cows provided with either fresh feed upon return from milking or fresh feed 6 h after milking. Feeding time was averaged for 7 d per treatment for 48 cows (4 groups of 12) fed twice a day.

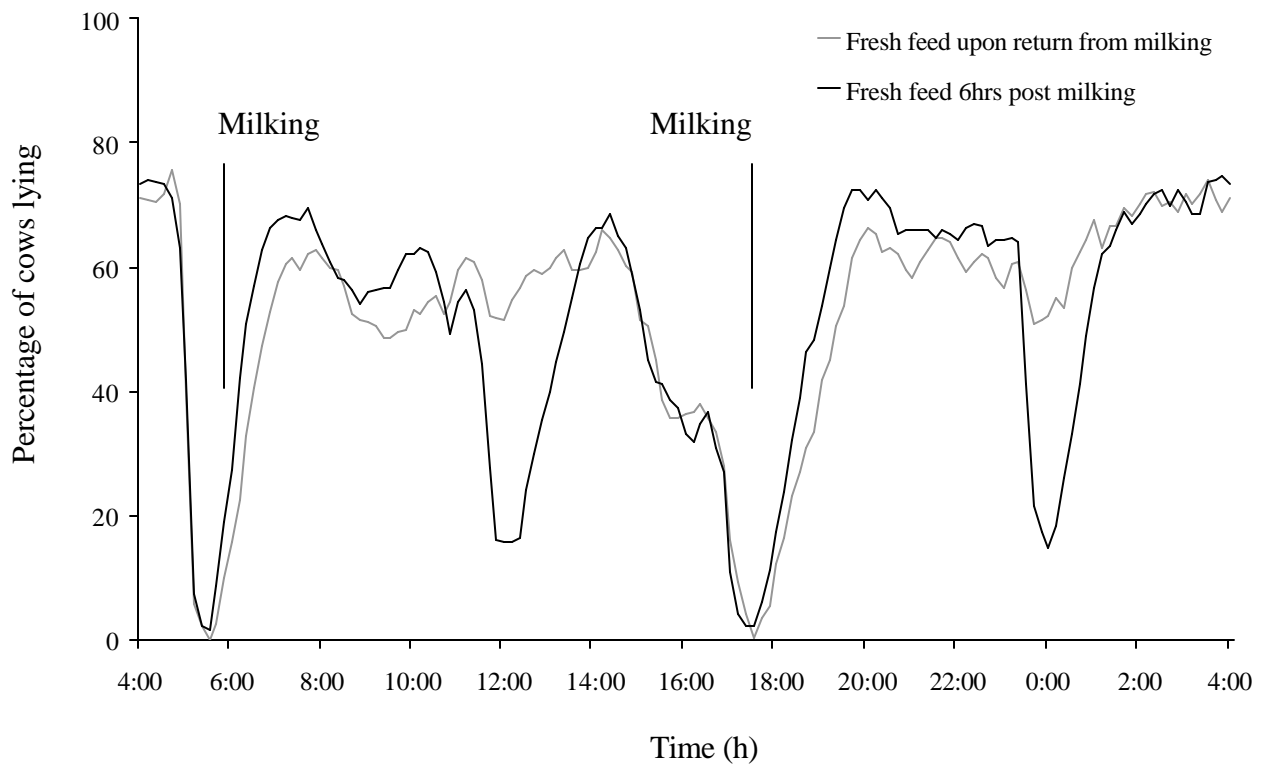

Figure 3.3. Percentage of cows per group lying over a 24-h period (percentage for each 10-min interval during the day) for 2 treatments: 1) cows were milked and fed at 0530 and 1730 h, and 2) cows were milked at 0530 and 1730 h and fed at 1130 and 2130 h. Data are averaged for 7 d per treatment for 4 groups, each containing 12 cows. Data are presented from 0400 h, since this was a time of stable lying activity for both treatments.

3.7 REFERENCES

- Albright, J. L. 1993. Feeding behavior of dairy cattle. *J. Dairy Sci.* 76:485-498.
- Canadian Council on Animal Care. 1993. Guide to the care and use of experimental animals. Vol. 1. E. D. Olfert, B. M. Cross, and A. A. McWilliam, ed. CCAC, Ottawa, Canada.
- DeVries, T. J., M. A. G. von Keyserlingk, and K. A. Beauchemin. 2003a. Diurnal feeding pattern of lactating dairy cows. *J. Dairy Sci.* 86:4079-4082
- DeVries, T. J., M. A. G. von Keyserlingk, D. M. Weary, and K. A. Beauchemin. 2003b. Measuring the feeding behavior of lactating dairy cows in early to peak lactation. *J. Dairy Sci.* 86:3354-3361.
- DeVries, T. J., M. A. G. von Keyserlingk, D. M. Weary, and K. A. Beauchemin. 2003c. Validation of a system for monitoring feeding behavior of dairy cows. *J. Dairy Sci.* 86:3571-3574.
- DeVries, T. J., M. A. G. von Keyserlingk, and D. M. Weary. 2004. Effect of feeding space on the inter-cow distance, aggression, and feeding behavior of free-stall housed Holstein dairy cows. *J. Dairy Sci.* 87:1432-1438.
- Fregonesi, J.A., C. B. Tucker, D. M. Weary, F. C. Flower, and T. Vittie. 2004. Effect of rubber flooring in front of the feed bunk on the behavior of dairy cattle. *J. Dairy Sci.* 87:1203-1207.
- Hafez, E. S. E., and M. F. Bouissou 1975. The behaviour of cattle. Pages 203-245 in *The behaviour of domestic animals*. 3rd ed. E. S. E. Hafez, ed. Bailliere Tindall, London, UK.
- Haley, D.B., J. Rushen, and A.M. de Passille. 2000. Behavioral indicators of cow comfort: Activity and resting behaviour of dairy cows housed in two types of housing. *Can. J. Anim. Sci.* 80:257-263.
- Johansson, B., I. Redbo, and K. Svennersten-Sjaunja. 1999. Effect of feeding before, during and after milking on dairy cow behaviour and the hormone cortisol. *Animal Science*. 68:597-604.
- National Research Council. 2001. Nutrient requirements for dairy cattle. *Natl. Acad. Sci.* Washington, DC.
- McDonald, J. S. 1975. Radiographic method for anatomic study of the teat canal: Changes between milking periods. *Am. J. Vet. Res.* 36:1241-1242.
- SAS User's Guide: Statistics, Version 5 Edition. 1985. SAS Inst., Inc., Cary, NC.
- Schultz, T. A. 1985. Feeding affects post-milking cow activities. *California Agriculture*. 39:29-30.

Schultze, W. D., and S. C. Bright. 1983. Changes in penetrability of bovine papillary duct to endotoxin after milking. *Am. J. Vet. Res.* 44:2373-2375.

Tanida, H., L. V. Swanson, and W. D. Hohenboken. 1984. Effect of artificial photoperiod on eating behavior and other behavioral observations of dairy cows. *J. Dairy Sci.* 67:585-591.

Tyler, J. W., L. K. Fox, S. M. Parish, J. Swain, D. L. Johnson, H. A. Grasseschi, and R. Gant. 1997. Effect of feed availability on post-milking standing time in dairy cows. *J. Dairy Res.* 64:617-620.

Wagner-Storch, A. M., and R. W. Palmer. 2003. Feeding behavior, milking behavior, and milk yields of cows milked in a parlor versus an automatic milking system. *J. Dairy. Sci.* 86:1494-1502.

CHAPTER 4: Frequency of feed delivery affects the behavior of lactating dairy cows^{3?}

4.1 INTRODUCTION

Considerable research to date has been focused on improving DMI of lactating dairy cows by changing the nutrient composition of feeds. However, the DMI of group-housed lactating dairy cows is also affected by feeding behavior, which is in turn modulated by the environment, management, health, and social interactions (Grant and Albright, 2000). Previous research by our group indicated that feeding activity in cows is stimulated by the delivery of feed and by the return from milking (DeVries et al., 2003a). The delivery of feed was further shown to have the greatest impact in terms of stimulating dairy cows to feed (DeVries and von Keyserlingk, 2005).

The majority of lactating dairy cows in North America are fed a TMR offered ad libitum. Nocek and Braund (1985) suggested that feeding a TMR is the optimal way to provide the balance of nutrients ruminants need to maintain a stable and efficient microbial population. These authors also indicated that the availability of the feed over time and the distribution of intake over the course of the day may further contribute to the maintenance of a stable ruminal microbial population. Provision of the TMR in conventional feeding schedules of lactating dairy cattle for most dairy operations remains at twice per day (2x). However, many producers elect to feed their cows only once per day (1x) to reduce labor costs. The feeding behavior response elicited by cows to the delivery of fresh feed may, therefore, result in slug feeding when feed is only provided 1x, which could predispose a cow to sub-acute ruminal acidosis (Shaver, 2002). Since the delivery of feed stimulates feeding activity (DeVries and von Keyserlingk, 2005) and is also associated with increased aggressive behavior between group-housed animals (Jeziarski and

³A version of this chapter has been published. DeVries, T. J., M. A. G. von Keyserlingk, and K. A. Beauchemin. 2005. Frequency of feed delivery affects the behavior of lactating dairy cows. *J. Dairy Sci.* 88:3553-3562.

Podluzny, 1984), it follows that a low frequency of feed delivery may result in increased competition among cows. Furthermore, increased competition may lead to some cows modifying their feeding times to avoid aggressive interactions (Miller and Wood-Gush, 1991).

Alternatively, it could be hypothesized that with more frequent offerings of feed, the distribution of feeding time and intake would be more evenly spread throughout the day. Further, a steady input of nutrients into the rumen over the course of the day would stabilize rumen pH (French and Kennelly, 1990), which, in turn may reduce the risk for sub-acute ruminal acidosis. There appears to be little work addressing the effects of frequency of feed delivery on the behavior of group-housed lactating dairy cattle, in particular, the distribution of daily feeding time and the level of competition at the feed bunk.

Questions can also be raised regarding the effect of frequency of feed delivery on the quality of the TMR available to the cows over the course of the day. Cows have been shown to preferentially sort for the grain component of a TMR, leaving the longer forage components. This behavior results in an increase in the fiber content of the remaining feed (Leonardi and Armentano, 2003), with the greatest effect thought to occur when frequency of feed delivery is low (Shaver, 2002).

Therefore, the first objective of this study was to examine how the frequency of feed delivery affects the behavior of group-housed lactating dairy cows. The second objective of this study was to examine how frequency of feed delivery affects the extent of feed sorting. These objectives were tested in two experiments, the first comparing the effects of delivering feed 1x to 2x, and the second comparing the effects of delivering feed 2x to four times per day (4x).

4.2 MATERIALS AND METHODS

4.2.1 Animals, Housing, and Diet

Eleven primiparous and 37 multiparous (parity = 3.5 ± 1.3 ; mean \pm SD) lactating Holstein dairy cows were used for two experiments. For the first experiment, the animals were 139.5 ± 18.1 DIM at the beginning of the data collection period and had an average milk yield of 42.5 ± 8.5 kg/d over the course of the experiment. For the second experiment, the animals were 165.5 ± 18.1 DIM at the beginning of the data collection period and had an average milk yield of 40.6 ± 7.7 kg/d over the course of the experiment. For both experiments, the animals were divided into 4 equal groups of 12 cows, which were balanced according to DIM, projected 305 d milk production ($11,409.4 \pm 1874.4$ kg), and average parity (2.9 ± 1.6). These groups were created by blocking cows into groups of 4 cows (similar in parity, DIM, and projected 305d milk production), and then randomly assigning the cows in these blocks to 1 of the 4 experimental groups. All groups were housed together for 1 wk to allow for social adaptation prior to data collection in the first experiment, and remained together until the end of the second experiment. The experiments were conducted between January 18, 2004 and March 3, 2004. The average environmental temperature during this experiment was 5.5°C , with a minimum of -10.5°C and maximum of 15.5°C .

The cows were housed in a free-stall barn located at The University of British Columbia Dairy Education and Research Centre (Agassiz, BC, Canada) and were managed according to the guidelines set by the Canadian Council on Animal Care (1993). In both experiments, cows were fed ad libitum a TMR (Table 4.1). In Experiment 1 the TMR contained, on a DM basis, 51.2% concentrate and 48.8% forage and in Experiment 2 the TMR contained, on a DM basis, 52.2% concentrate and 47.8% forage. Diets were formulated according to the NRC (2001) nutrient

requirement recommendations for high producing dairy cows. Cows had access to the feed bunk via a post-and-rail feed barrier (with a pendulous feed rail) and had 0.6 m of feeding space per animal. In both experiments, feed push-ups occurred to ensure that feed was available to the cows for all hours in the day in which they were in their respective pen. Each cow had access to a free stall that was deep bedded with sand. Animals were milked between 0500 and 0530 h in the morning and between 1700 and 1730 h in the afternoon. Milk yields were automatically recorded at each milking.

4.2.2 Experimental Treatments and Design

In Experiments 1 and 2, the 48 lactating cows were used in a cross-over design. Each group was subjected to each of 2 treatments in each experiment. Initially, each of the 2 treatments was applied to 2 groups of cows for a 3-d adjustment period followed by 7 d of data collection. Treatments were then switched between the groups. Again, animals had a 3-d adjustment period followed by 7 d of observations on the new treatment. Since the groups were housed in adjacent pens, treatments were alternated between groups so that adjacent groups were always on different treatments.

4.2.2.1 Experiment 1. Treatments were: 1) delivery of feed 1x (at 0530 h), and 2) delivery of feed 2x (at 0530 and 1515 h). When groups were fed 1x, feed was pushed-up at 1100, 1515 and 2230 h. When groups were fed 2x, feed was pushed up at 1100 and 2230 h.

4.2.2.2 Experiment 2. Treatments were: 1) delivery of feed 2x (at 0530 and 1515h), and 2) delivery of feed 4x (at 0530, 1100, 1515, and 2230 h). When groups were fed 2x, feed was pushed up at 1100 and 2230 h. No feed push-up occurred when cows were fed 4x.

In Experiment 1, for the 1x treatment, the TMR was mixed in the morning immediately prior to its delivery to the cows. For the 2x treatment, in both experiments, the TMR for the 0530 h feeding was mixed immediately prior to its delivery to the cows. The TMR for the 1515 h feeding was mixed at approximately 1030 h and kept in the mixer wagon until the time of feed delivery. In Experiment 2, for the 4x treatment, the TMR was mixed twice daily. The TMR for the 0530 h and 1100 h feedings was mixed immediately prior to the 0530 h feeding. The TMR used in the 1100 h feeding was kept in the mixer wagon until the time of delivery. The TMR for the 1515 h and 2230 h feedings was mixed at approximately 1030 h. The TMR for the 1515 h feeding was then kept in the mixer wagon until the time of delivery, while the TMR for the 2230 h feeding was stored in a bunker silo until approximately 1900 h, at which time it was transferred to the mixer wagon and was kept there until it was delivered to the cows.

4.2.3 Feed Sampling and Analyses

For both experiments, representative samples of the TMR were taken for each group at the time of each feed delivery, feed push-up, and from the orts for d 1, 3, 5, and 7 of each treatment period in each experiment. The TMR was sub-sampled by taking grab samples from three different locations along the entire feed bunk. Care was taken that each grab sample represented the top, middle and bottom of the TMR along the feed bunk. Dry matter content of the samples was determined by oven-drying at 60°C for 3 d. The dried samples were then ground to pass through a 1-mm screen (Wiley mill, standard model 4; Arthur H. Thomas Co., Philadelphia, PA). Analytical DM content of the samples was determined by drying at 135°C for 3 h (AOAC, 1990). The OM content was calculated as the difference between DM and ash contents, with ash determined by combustion at 550°C for 5 h. The NDF and ADF contents were

determined using an ANKOM²⁰⁰ Fiber Analyzer (ANKOM Technology, Fairport, NY) according to the methodology supplied by the company, which is based on the methods described by Van Soest et al. (1991). Heat-stable alpha-amylase and sodium sulfite were used in the NDF procedure. For the measurement of CP (N x 6.25), content of N in the samples was determined by flash combustion using a Model NA 2100 Protein CHN Analyzer (Carlo Erba Instruments, Milan, Italy).

Dry matter intake for each group for each day on treatment was recorded by subtracting the DM weight of the orts from the DM weight of the delivered feed. The daily orts averaged 5.2 ± 5.1 (mean \pm SD) % and 7.9 ± 4.8 % of the delivered feed provided over the course of Experiment 1 and Experiment 2, respectively.

4.2.4 Behavioral Recording

All behaviors were monitored using time-lapse video equipment. The feeding and lying behavior of the cows were recorded continuously for 7 d per treatment. The aggressive behavior of the cows was recorded continuously for the last 3 d of the observation period for each treatment. The animals were videotaped using 2 video cameras (Panasonic WV-BP330; Osaka, Japan) per pen, a time-lapse videocassette recorder (Panasonic AG-6540) and a video multiplexer (Panasonic WJ-FS 216). For each pen, a video camera was located 6 m above the feed bunk and another 10 m above the lying areas of the pen. Red lights (100 W) were used to facilitate recording at night. Individual animals were identified with unique alphanumeric symbols made with hair dye (Clairol's Nice and Easy # 122, Natural Black, or Clairol's L'image Maxiblond, depending on hair color; Stamford, Connecticut) on the back of the cows.

4.2.4.1 Measuring feeding behavior. The feeding behavior of individual cows was scored from video using instantaneous scan sampling once every 10 min. For each scan, an animal was recorded as feeding when its head was completely past the feed rail and over the feed. These scans were then used to calculate the total time spent feeding by multiplying the number of scans by 10 (Endres et al., 2005). The time spent feeding was calculated for each cow for each treatment day. This measure of feeding behavior has previously been shown to be the most repeatable measure of feeding behavior and sensitive for detecting treatment differences (DeVries et al., 2003b). Additionally, to detect changes in the distribution of daily feeding time, we calculated the feeding time for the cows during the daytime and early evening hours (0600 to 2000 h), the late evening and early morning hours (2000 to 0600 h) and for the 90 min after the time of feed delivery (which was identified as a period of peak feeding activity).

4.2.4.2 Measuring lying behavior. Daily lying times of individual cows were obtained from the video recordings, using instantaneous scan sampling once every 10 min. These scans were then used to calculate the total time spent lying by multiplying the number of scans by 10 (Fregonesi et al., 2004). The time spent lying was calculated for each cow for each treatment day. In addition to this, the length of time it took cows to lie down upon return from the milking parlor (i.e. latency to lie) was obtained. This was quantified by continuously watching the video recordings from the time the cows returned from the parlor until they lay down in one of the free stalls.

4.2.4.3 Measuring aggressive behavior. The total daily number of aggressive displacements at the feed bunk was recorded. A displacement was noted when a butt or a push from the actor (instigator) resulted in the complete withdrawal of the reactor's head from beneath the feed rail (DeVries et al., 2004).

4.2.5 Data Analyses

For the analyses of feeding behavior, DMI, lying behavior, and aggressive behavior, the pen was considered as the experimental unit, with measures from multiple days and cows averaged to create one observation per pen per treatment. For Experiment 1, there was an interaction between treatment and the milking time (i.e. a.m. or p.m.) for the latency to lie down data; consequently, these data were summarized and analyzed separately for each milking. Treatment effects on the feeding behavior measures, DMI, lying behavior measures, number of displacements were tested by one-sample paired *t*-tests with 3 df. Least square means and standard errors were determined using the LSMEANS and STDERR statement in PROC GLM (SAS, 1999). Overall, treatment response was tested using the pen as the experimental unit. However, we predicted that the cows with low feeding times and the cows that were displaced from feed bunk most often would be most affected by treatment, and therefore we used a within-cow test to analyze this. Feeding times (for the 90 min after feed delivery and for the late evening and early morning hours (2000 to 0600 h)) and the frequency at which cows were displaced from the feed bunk during the 2 treatments, in each experiment, were compared using the regression procedure of SAS (1999). To determine if cows changed on average, the intercept was tested for difference from zero, and to determine the extent of the change relative to the initial value, the slope was tested for difference from one.

For the analysis of the NDF content of the TMR samples, the pen was considered as the experimental unit, with measures from multiple days averaged to create one observation per pen per treatment per sampling time. Treatment effects were tested in a mixed model. Compound symmetry was selected as the covariance structure on the basis of best fit using the PROC

MIXED procedure of SAS (1999). Subsequent analyses were performed with PROC GLM, which uses the compound symmetry structure as default and allowed us to model the sampling time as a continuous variable. The model tested the terms for pen (3 df), treatment (1 df), linear effect of sampling time (1 df), quadratic effect of sampling time (1 df), and the interaction between treatment and the quadratic effect of sampling time (1 df), against the residual error (32 df). Least square means and standard errors were determined using the LSMEANS and STDERR statement in PROC GLM.

4.3 RESULTS

4.3.1 Feeding Behavior and Feed Intake

During Experiment 1, cows fed 2x increased their daily feeding time by 10 min compared to when they were fed 1x (Table 4.2). This increase was primarily attributed to the tendency for cows to increase their feeding time during the late evening and early morning hours (i.e. 2000 to 0600 h). Linear regression was used to determine how individual cows changed their feeding times during these hours. Feeding times during this time period were highly related for the 2 treatment conditions ($R^2 = 0.54$, $P < 0.001$). The slope (0.76 ± 0.10) for the linear relationship was less than one ($P = 0.02$), and the intercept (21.01 ± 5.66) was greater than zero ($P < 0.001$). Despite finding no difference in feeding time during the daytime and early evening hours, there were differences in the distribution of the feeding time during these times. Cows tended to spend more time feeding during the 90 min following the delivery of feed when they were fed 1x than when they were fed 2x (Table 4.2). These differences are illustrated in the feed bunk attendance patterns (see Figure 4.1a). Linear regression was used to determine how individual cows changed their feeding times during these peak feeding periods. Feeding times during this time period were

highly related for the 2 treatment conditions ($R^2 = 0.51$, $P < 0.001$). The slope (0.52 ± 0.07) for the linear relationship was less than one ($P < 0.001$), and the intercept (18.40 ± 4.04) was greater than zero ($P < 0.001$).

When cows were provided feed 4x in Experiment 2, they increased their daily feeding time by 14 min compared to when they were fed 2x (Table 4.2). Most of this increase was the result of an increase in feeding time during the late evening and early morning hours. Linear regression was used to determine how individual cows changed their feeding times during these hours. Feeding times during this time period were highly related for the 2 treatment conditions ($R^2 = 0.46$, $P < 0.001$). The slope (0.81 ± 0.13) for the linear relationship was not different from one ($P = 0.16$), and the intercept (26.27 ± 7.33) was greater than zero ($P < 0.001$). As in Experiment 1, despite finding no difference in feeding time during the daytime and early evening hours, there were differences in the distribution of the feeding time during these hours. Cows spent more time feeding during the 90 min following the delivery of feed when fed 2x than when fed 4x (Table 4.2). These differences are illustrated in the feed bunk attendance patterns (see Figure 4.1b). Linear regression was used to determine how individual cows changed their feeding times during these peak feeding periods. Feeding times during this time period were highly related for the 2 treatment conditions ($R^2 = 0.66$, $P < 0.001$). The slope (0.60 ± 0.06) for the linear relationship was less than one ($P < 0.001$), and the intercept (11.19 ± 3.27) was greater than zero ($P = 0.001$).

There was no difference in DMI when groups were fed 1x compared to when they were fed 2x (24.6 ± 0.7 kg versus 24.1 ± 0.7 kg/cow/d, respectively; $P = 0.7$). There was also no difference in DMI when groups were fed 2x compared to when they were fed 4x (22.9 ± 0.4 kg versus 22.2 ± 0.4 kg/cow/d, respectively; $P = 0.3$).

4.3.2 Lying Behavior

During both Experiments 1 and 2, the frequency of feed delivery had no effect on the length of time cows spent lying per day (Table 4.3). In Experiment 1 there was no effect of treatment on the pattern of lying time throughout the day (Figure 4.2a), but when cows were fed 1x, they took longer to lay down after the a.m. milking compared to when they were fed 2x (Table 4.3). In Experiment 2, the pattern of lying time throughout the day was affected by the frequency of feed delivery. When cows were fed 4x, they showed 4 periods of lying activity compared to the 2 extended periods of lying activity when they were fed 2x (Figure 4.2b). It is also interesting to note that when the cows received feed 4x, they had a decreased latency to lie down after milking compared to when they were fed 2x (Table 4.3).

4.3.3 Aggressive Behavior

In Experiment 1, there was no difference in the frequency of displacements at the feed bunk when cows were fed 1x compared to 2x (9.6 versus 8.7 displacements/cow/day; SE = 0.7; $P = 0.4$). Linear regression indicated that the frequency of displacements was highly related for the 2 treatments ($R^2 = 0.60$, $P < 0.001$) and varied between cows depending on treatment. The slope (0.70 ± 0.08) for the linear relationship was less than one ($P < 0.001$), and the intercept (1.97 ± 0.93) was greater than zero ($P = 0.04$).

Similarly, for Experiment 2, there was also no difference in the frequency of displacements at the feed bunk when cows were fed 2x compared to 4x (7.5 versus 7.7 displacements/cow/day; SE = 1.1; $P = 0.9$). Linear regression for this experiment also indicated that the frequency of displacements was highly related for the 2 treatments ($R^2 = 0.43$, $P < 0.001$)

and varied between cows depending on treatment. The slope (0.64 ± 0.11) for the linear relationship was less than one ($P = 0.002$), and the intercept (2.94 ± 0.96) was greater than zero ($P = 0.004$).

4.3.4 Fiber Content of the TMR

For Experiment 1, analysis of NDF content of the TMR over the day indicated no effect of treatment, however, there was an effect (linear effect: $P < 0.001$; quadratic effect: $P = 0.003$) of sampling time. Further, there was an interaction ($P = 0.017$) between treatment and the quadratic effect of sampling time. This indicated that the NDF content of the TMR in the feed bunk increased in a curvilinear manner throughout the day for both the 1x ($y = 0.53x^2 - 1.57x + 35.78$, $R^2 = 0.98$) and 2x ($y = 0.39x^2 - 1.58x + 36.62$, $R^2 = 0.83$) treatments, however, the effect was greatest when feed was delivered 1x (see Figure 4.3a).

Similarly in Experiment 2, analysis of NDF content indicated no effect of treatment, but there was an effect (linear effect: $P < 0.001$; quadratic effect: $P = 0.019$) of sampling time. Again, this indicated that the NDF content of the TMR in the feed bunk increased in a curvilinear manner throughout the day for both the 2x ($y = 0.39x^2 - 1.28x + 34.86$, $R^2 = 0.71$) and 4x ($y = 0.34x^2 - 1.22x + 35.23$, $R^2 = 0.75$) treatments (see Figure 4.3b).

Changes in the forage to concentrate ratio of the TMR were estimated by calculating the forage to concentrate ratio of the orts. This calculation was performed using the initial NDF content values for the feed components and the final NDF content of the orts. In Experiment 1, the TMR for both 1x and 2x treatments initially had a forage to concentrate ratio, on a DM basis, of 49:51, however, the remaining orts for the 1x and 2x treatments had a calculated ratio of 63:37 and 55:45, respectively. In Experiment 2, the TMR for both 2x and 4x treatments initially had a

forage to concentrate ratio, on a DM basis, of 48:52. The orts were calculated to have a forage to concentrate ratio of 58:42 and 57:43 for the 2x and 4x treatments, respectively.

4.4 DISCUSSION

During the past few years there has been increased interest in determining the effects that frequency of feed delivery has on lactating dairy cattle. This interest may, in part, be attributed to many producers electing to deliver the daily allotment of TMR 1x as a means of reducing labor costs. Previous research in this area has been focused on the effects on milk production and DMI, and reported variable results (see Gibson, 1984; Nocek and Braund, 1985; Shabi et al., 1999; Dhiman et al., 2002). Much of this variation can be attributed to differences in methodology (e.g. experimental procedures, breeds of cows, diet composition, feeding level). Furthermore, the majority of the experimental conditions described in these studies (e.g. tie stall housing) may not be applicable to today's dairy operations. Many modern dairy operators group house their dairy cattle in free-stall barns. It can be surmised that the frequency of feed delivery may have different effects for group-housed cattle, specifically due to the social facilitation that exists in this setting (Miller and Wood-Gush, 1991). From the literature there is little indication to what effect frequency of feed delivery has on the behavior of group-housed lactating dairy cattle.

In the present study, it was evident that group-housed dairy cows increased their daily feeding time with increased frequency of feed delivery. This finding contradicts previous work reported by Phillips and Rind (2001), who compared the effects of 1x and 4x feeding on group-housed cattle, and found no effect on daily feeding time. This discrepancy in results may be attributed to differences in experimental methodologies and conditions present in the two studies. Phillips and Rind (2001) based their feeding behavior data on only 1 d of observations per

treatment. Unfortunately, since there is considerable within-cow day-to-day variation in feeding behavior data, statistical significance in studies based on 1 d of data can only be achieved when treatment differences are large (Dado and Allen, 1994). Further, the DMI and production level of the cows were very low in comparison to that observed in the present study. Cows with low DMI and milk production may not have the same motivation to feed and, therefore, may not respond to increased frequency of feed delivery by increasing their feeding time as much as cows with high DMI and milk production. Time spent feeding has also been shown to be correlated with milk production (Shabi et al., 2005). It follows that milk production may be increased by encouraging cows to spend more time feeding (Shabi et al., 2005). Therefore, it is possible that the high feeding times seen in the present study in response to high frequency of feed delivery could translate into increased milk production over a longer period of time.

In both Experiments 1 and 2, most of the daily increase in feeding time in response to increased frequency of feed delivery was the result of an increase in feeding time during the late evening and early morning hours (i.e. 2000 to 0600 h). This result agrees with the finding of Phillips and Rind (2001), who reported that cows which were fed frequently tended to spend less time feeding in the morning and a longer time feeding in the late evening.

Several researchers have shown that increasing frequency of feed delivery can reduce the diurnal fluctuations in rumen pH. French and Kennelly (1990) found that the postprandial pH in dairy cows fed concentrate 2x was depressed for a few hours before returning to the pre-feeding values. In that same study, the postprandial decline in rumen pH was virtually eliminated when animals were fed concentrate 12 times daily. Similarly, Shabi et al. (1999) compared 2x to 4x feeding of a TMR and found that the diurnal variation in ruminal pH was significantly reduced when lactating cows were fed 4x. In the present study, increasing the frequency of feed delivery

resulted in a more even distribution of feeding time over the course of the day. This may contribute to decreased diurnal variation in ruminal pH, which in turn may possibly reduce the risk for sub-acute ruminal acidosis.

The regression analysis of the data from the peak feeding periods in Experiment 1 and 2 indicated that those cows with high feeding times when fed 1x and 2x decreased their feeding times when fed 2x and 4x, respectively. However, it also indicated that those cows with low feeding times when fed 1x and 2x, increased their feeding times during these periods when fed 2x and 4x, respectively. These results indicate that increasing the frequency of feed delivery allows for more equal access to fresh feed. This is particularly important, as it has been demonstrated that the delivery of fresh feed has the greatest effect in terms of stimulating feeding activity in group-housed dairy cattle (see DeVries and von Keyserlingk, 2005).

In both Experiments 1 and 2, group feed intakes were used to calculate the average DMI per cow per treatment, and we found no effect of treatment on this measure for either experiment. However, we caution the interpretation of these results since these experiments were designed to test predictions concerning feeding behavior, and do not provide a strong test of intake differences. The regression analysis of the feeding behavior data indicated that cows varied in their distribution of daily feeding time, and this same variation may also have occurred in the distribution of DMI.

It is interesting to note that in both experiments, despite the increases in feeding time with increased frequency of feed delivery, there was no change in total daily lying time. This indicates that with increased frequency of feed delivery, cows are able to increase the amount of time that they spent feeding and reduce the amount of time that they spent idle waiting for feed or to access the feed bunk. The daily distribution of lying time was, however, influenced by frequency

of feed delivery. In Experiment 1, the cows took 13 min longer to lie down after the a.m. milking when fed 1x compared to when fed 2x. This reflected the tendency for cows to spend a longer time feeding during the 90-min period following feed delivery when they were fed 1x. Interestingly, the latency to lie down after the p.m. milking was not different between the 1x and 2x treatments. This is most likely due to the fact that when cows were fed 2x, they had over 90 min of access to their second daily delivery of feed prior to going to the milk parlor. In Experiment 2, when the cows were fed 2x, they took 11 min longer to lie down after milking compared to when they were fed 4x. Again, this reflects the fact that when the cows were fed 4x, they reduced the time spent feeding during the 90-min period following feed delivery. This further demonstrates that the cows more evenly distributed their feeding time over the course of the day when they were delivered feed at a higher frequency.

The frequency of feed delivery did not affect the daily incidence of aggressive interactions at the feed bunk in either experiment. This result agrees with the finding of Phillips and Rind (2001), who reported no effect of frequency of feed delivery on the daily number of aggressive interactions. Despite this, the regression analyses undertaken in both experiments indicated that the cows in the present study that were displaced least often from the feed bunk during the low frequency of feed delivery treatment were displaced at a slightly higher frequency when exposed to the higher frequency of feed delivery treatments. The analyses also indicated that the cows that were displaced at the highest rate during the low frequency treatment, in each experiment, were displaced much less frequently when exposed to the higher frequency of feed delivery treatments. Therefore, the subordinate cows were not displaced as frequently when they were fed more often. This finding indicates that increasing the frequency of feed delivery may be

particularly useful in allowing all cows to feed when they want to, without the fear of being displaced.

Leonardi et al. (2005) suggest that longer particles are typically higher in NDF concentration than the TMR, and therefore, refusal of long particles can reduce total NDF intake. Further, several researchers have demonstrated that sorting can be signified by disparities between NDF concentrations in the diet and the orts (e.g. Onetti et al., 2004; Kononoff and Heinrichs, 2003; Kononoff et al., 2003). Therefore, to assess the extent of sorting of the TMR in the present study, the NDF content of the TMR in the feed bunk was measured throughout the day. The analyses demonstrated that the NDF content of the TMR in the feed bunk increased in a curvilinear manner throughout the day for all treatments in both experiments. Similarly, in a study by Kononoff et al. (2003), where cows were fed 1x, it was demonstrated that the NDF content of the feed present in the bunk increased throughout the day following the initial feed delivery, indicating that feeding sorting had occurred.

In the present study, comparison of the calculated forage to concentrate ratio of the delivered feed and the orts in both treatments in each experiment also provides further evidence that sorting of the diet can lead to the cows consuming an inconsistent ration, as suggested by Stone (2004). Sorting typically occurs when cows discriminate against the longer forage components, resulting in some cows consuming much more grain than intended (Leonardi and Armentano, 2003). It is believed that cows consuming the increased amounts of grain and low amounts of fiber in situations where sorting behavior is evident are at increased risk for sub-acute ruminal acidosis (Cook et al., 2004; Stone, 2004). Alternatively, sorting of the TMR can reduce the quality of the feed, particularly in the later hours past the time of feed delivery, as seen in the present study. This may be detrimental for those cows that do not have access to feed at the time

when it is delivered. In such cases, these cows may not be able to maintain adequate nutrient intake to maintain high levels of milk production. The results of the present study indicate that increasing the frequency of feed delivery allows for more equal access to feed. The regression analyses of the feeding data during both the post feed delivery peak feeding periods and the late evening and early morning hours indicated that the higher frequency of feeding treatment, in each experiment, resulted in more equal feeding times between cows during these periods. This result, coupled with the finding that subordinate cows were not displaced as frequently when fed more often, indicate that providing feed more frequently may improve access to feed for all cows, especially during peak feeding periods when fresh feed is available. Therefore, higher frequencies of feed delivery have the potential to reduce the variation in diet quality consumed by the cows.

Improving access to feed may be particularly important when feed is delivered at low frequencies. In Experiment 1, the interaction between the TMR sampling time and frequency of feed delivery indicated that more sorting occurred when feed was delivered 1x. This translated into theorts containing 8% more forage when the cows were fed 1x compared to when fed 2x. This result supports the suggestion by Shaver (2002) that the effect of sorting is greater when frequency of feed delivery is low. Therefore, the amount of sorting of a TMR by lactating dairy cows can be reduced by increasing the frequency of feed delivery from 1x to 2x.

4.5 CONCLUSIONS

In both Experiment 1 and 2, increasing the frequency of feed delivery from 1x to 2x and 2x to 4x, respectively, allowed the cows to increase their daily feeding time, and increase the distribution of feeding time over the course of the day. The changes in distribution of feeding

time resulted in cows having more equal access to feed. The frequency of feed delivery did not affect the daily incidence of aggressive interactions at the feed bunk in either experiment. Despite this, we did find that subordinate cows were not displaced as frequently when fed more often. For all treatments in both experiments, the NDF content of the TMR in the feed bunk increased throughout the day, indicating that sorting of the TMR occurred. Additionally, the amount of sorting of a TMR was reduced by increasing the frequency of feed delivery from 1x to 2x. We, therefore, recommend delivering feed more frequently than 1x to improve access to fresh feed for all cows and reduce sorting. This will potentially reduce the variation in diet quality consumed by the cows.

4.6 ACKNOWLEDGEMENTS

We thank the staff and students at The University of British Columbia's Dairy Education and Research Centre and the University's Animal Welfare Program. In particular we thank Danica Olenick, Kiyomi Ito and Dineke van den Hazel for their help with running the experiments and with the video analysis. We also thank Bev Farr and Alastair Furtado of the Lethbridge Research Centre for their assistance in performing laboratory analyses. Trevor DeVries was supported by a Natural Sciences and Engineering Research Council of Canada (NSERC) Canada Graduate Scholarship. The project was funded by the Agriculture and Agri-Food Canada/NSERC Research Partnership Support Program made possible by contributions from the Dairy Farmers of Canada.

Table 4.1. Ingredient and chemical composition of the total mixed ration.

Composition	Experiment 1	Experiment 2
Ingredient, %DM		
Corn silage	19.7	20.1
Grass silage	9.7	8.2
Alfalfa hay	8.8	8.6
3 rd cut grass hay	10.6	10.9
Barley/corn blend ¹	14.6	14.9
Concentrate mash ²	36.6	37.3
Chemical analyses ³		
DM, %	49.4	48.4
OM, % of DM	92.0	91.7
CP, % of DM	18.5	18.7
ADF, % of DM	20.3	19.6
NDF, % of DM	36.2	35.2
NDF from forages, % of NDF	71.8	70.4

¹Supplied by Unifeed Ltd. (Chilliwack, BC, Canada), containing (as-is): 30% steam-rolled corn, 70% steam-rolled barley.

²Supplied by Unifeed Ltd. (Chilliwack, BC, Canada), containing (as-is): 18% soybean meal, 14% barley, 13.2% steam-rolled barley, 12.0% rye/corn distillers, 11% Amipro (Unifeed Ltd., Chilliwack, BC, Canada), 9% canola meal, 5% mill screenings, 3% cane molasses, 2.8% limestone, 2% tallow, 2.0% saturated vegetable fat, 1.5% trace mineral/vitamin premix, 1.3% fishmeal, 1.2% Megalac (Church and Dwight Co., Princeton, NJ), 1.2% sodium bicarbonate, 1.2% Yea-Sacc Farm Pak (Alltech, Inc., Nicholasville, KY), 1.0% salt, 0.4 % dicalcium phosphate, 0.2% magnesium oxide.

³Values were obtained from chemical analyses of TMR samples.

Table 4.2. Daily feeding time, feeding time during the daytime and early evening hours, during the late evening and early morning hours and during the 90-min period following the delivery of feed for both treatments¹ in Experiment 1 and 2.

Experiment 1	Treatment		SE	<i>P</i>
	1x ²	2x ²		
Daily (min/d) ³	293.5	303.8	2.1	0.04
Daytime and early evening (min) ⁴	243.0	244.6	2.9	0.73
Late evening and early morning (min) ⁵	50.5	59.2	2.1	0.06
Delivery of fresh feed (min) ⁶	51.2	44.9	2.0	0.11
Experiment 2	2x	4x ²		
Daily (min/d) ³	305.5	319.7	2.8	0.04
Daytime and early evening (min) ⁴	253.4	251.0	3.8	0.68
Late evening and early morning (min) ⁵	52.1	68.7	1.4	0.003
Delivery of fresh feed (min) ⁶	48.9	40.5	1.4	0.02

¹Data were averaged for 7 d per treatment for 4 groups of cows (12 cows per group).

²1x = feed delivery once per day at 0530 h; 2x = feed delivery twice per day at 0530 and 1515 h; 4x = feed delivery four times per day at 0530, 1100, 1515, and 2230 h.

³Average feeding time per cow per day.

⁴Average feeding time per cow between the hours of 0600 and 2000 h.

⁵Average feeding time per cow between the hours of 2000 and 0600 h.

⁶Average feeding time per cow during the 90 min following the provision of fresh feed.

Table 4.3. Mean time spent lying per day and the latency to lie after the return from milking for both treatments¹ in Experiment 1 and 2.

Experiment 1	Treatment		SE	<i>P</i>
	1x ²	2x ²		
Lying time (h/d) ³	13.1	13.0	0.2	0.9
Latency to lie in a.m. (min) ⁴	70.7	57.7	1.7	0.01
Latency to lie in p.m. (min) ⁵	62.8	60.7	1.9	0.5
Experiment 2	2x	4x ²		
Lying time (h/d) ³	12.9	12.9	0.2	0.9
Latency to lie (min) ⁶	66.2	55.2	1.9	0.03

¹Data were averaged for 7 d per treatment for 4 groups of cows (12 cows per group).

²1x = feed delivery once per day at 0530 h; 2x = feed delivery twice per day at 0530 and 1515 h; 4x = feed delivery four times per day at 0530, 1100, 1515, and 2230 h.

³Average lying time per cow per day.

⁴Length of time cows took to lie down after returning from being milked in the a.m.

⁵Length of time cows took to lie down after returning from being milked in the p.m.

⁶Length of time cows took to lie down after returning from being milked.

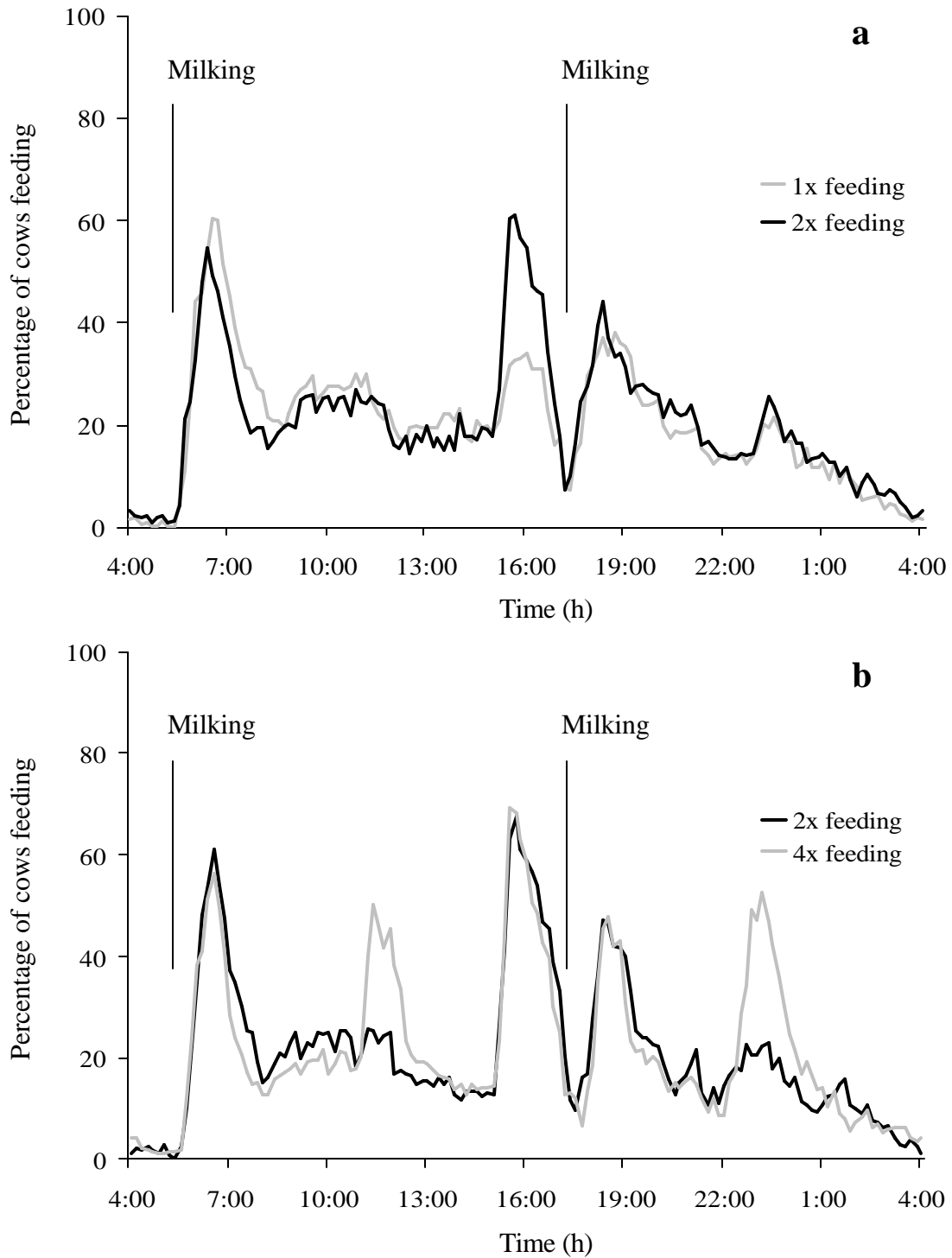

Figure 4.1. Percentage of cows per group present at the feed bunk over a 24-h period (percentage for each 10-min interval during the day) in (a) Experiment 1 for 2 treatments: 1) cows fed at 0530 h, and 2) cows fed at 0530 and 1515 h; and (b) Experiment 2 for 2 treatments: 1) cows fed at 0530 and 1515h, and 2) cows fed at 0530, 1100, 1515, and 2230 h. Data are averaged for 7 d per treatment for 4 groups, each containing 12 cows.

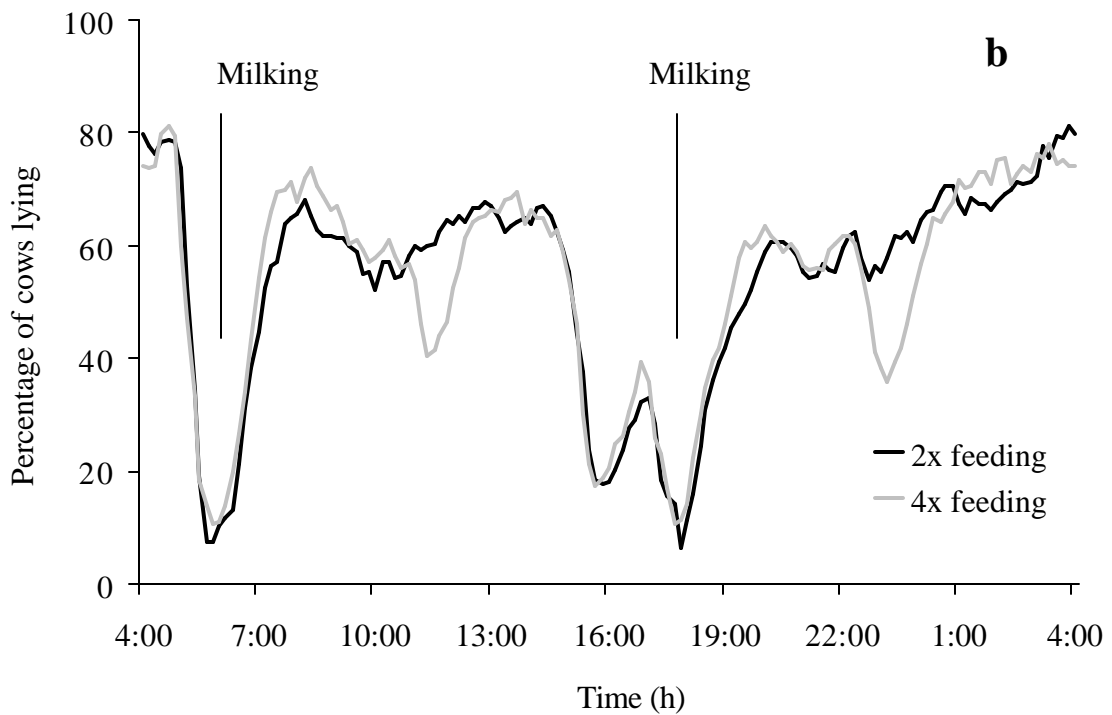
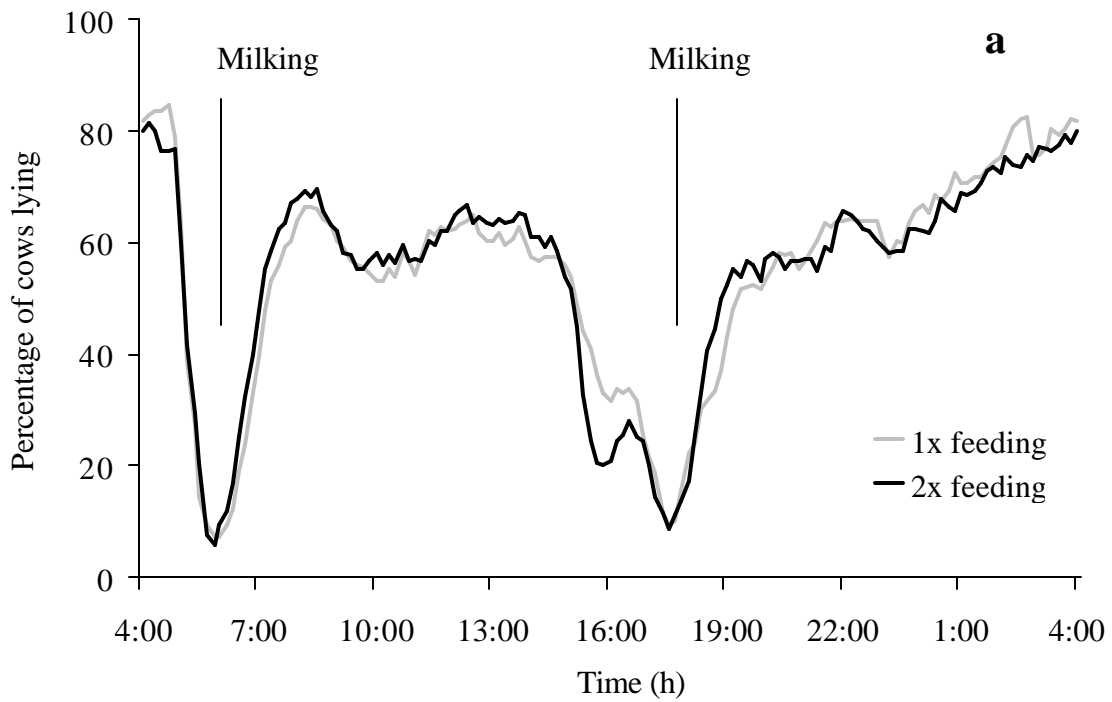

Figure 4.2. Percentage of cows per group lying down over a 24-h period (percentage for each 10-min interval during the day) in (a) Experiment 1 for 2 treatments: 1) cows fed at 0530 h, and 2) cows fed at 0530 and 1515 h; and (b) Experiment 2 for 2 treatments: 1) cows fed at 0530 and 1515h, and 2) cows fed at 0530, 1100, 1515, and 2230 h. Data are averaged for 7 d per treatment for 4 groups, each containing 12 cows.

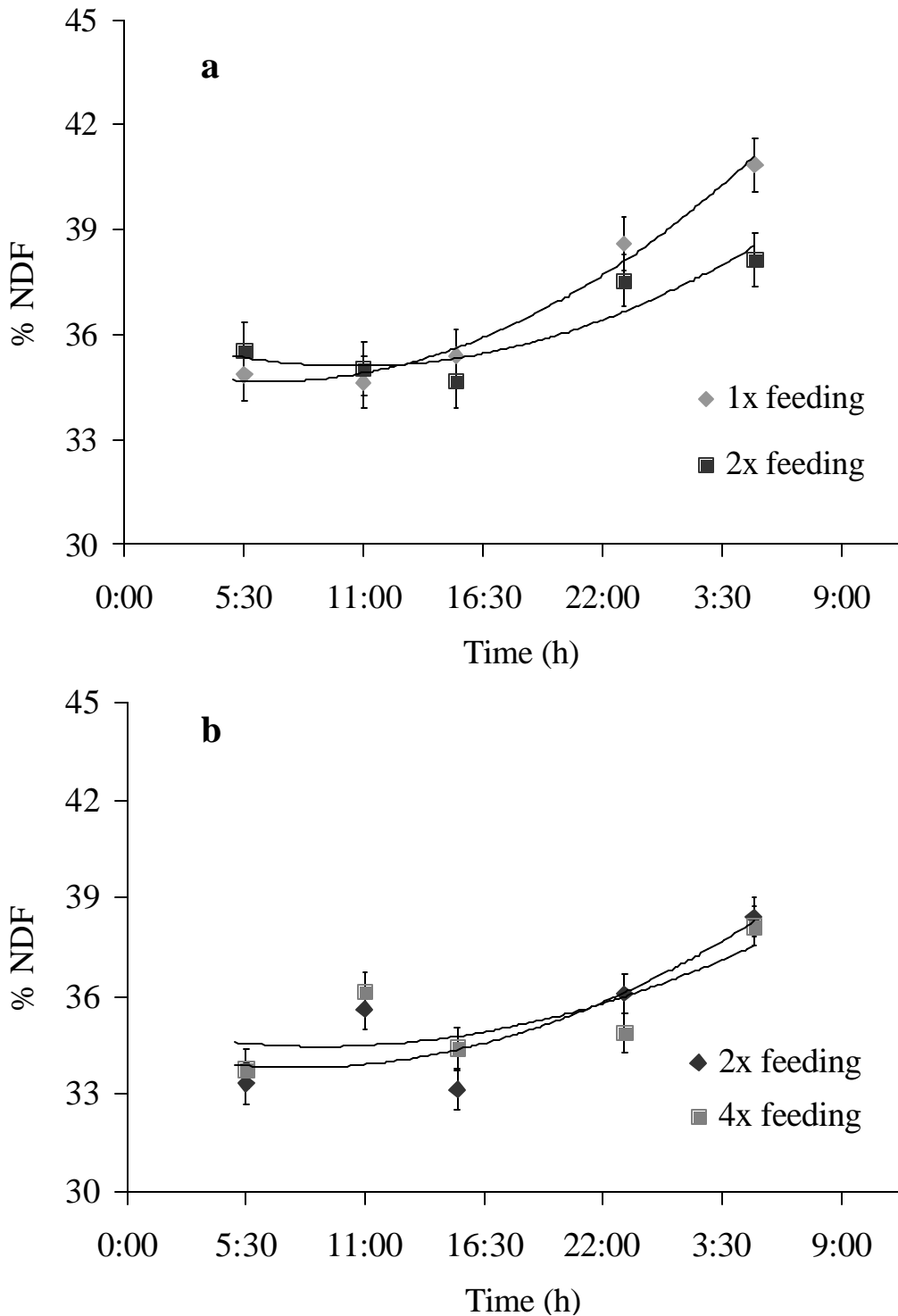

Figure 4.3. Percentage NDF (DM basis) of the TMR in the feed bunk over the course of the day for: a) 2 treatments: 1) cows fed at 0530 h, and 2) cows fed at 0530 and 1515 h, and b) 2 treatments: 1) cows fed at 0530 and 1515 h, and 2) cows fed at 0530, 1100, 1515, and 2230 h. Data are averaged for 4 d per treatment for 4 groups, each containing 12 cows. Data, for each treatment, are fitted with predicted quadratic functions.

4.7 REFERENCES

- Association of Official Analytical Chemists. 1990. Official Methods of Analysis. AOAC, Arlington, VA.
- Canadian Council on Animal Care. 1993. Guide to the care and use of experimental animals. Vol. 1. E. D. Olfert, B. M. Cross, and A. A. McWilliam, ed. CCAC, Ottawa, Canada.
- Cook, N. B., K. V. Nordlund, and G. R. Oetzel. 2004. Environmental influences on claw horn lesions associated with laminitis and subacute ruminal acidosis in dairy cows. *J. Dairy Sci.* 87: E36-46E.
- Dado, R. G., and M. S. Allen. 1994. Variation in and relationships among feeding, chewing, and drinking variables for lactating dairy cows. *J. Dairy Sci.* 77:132-144.
- DeVries, T. J., M. A. G. von Keyserlingk, and K. A. Beauchemin. 2003a. Diurnal feeding pattern of lactating dairy cows. *J. Dairy Sci.* 86:4079-4082
- DeVries, T. J., M. A. G. von Keyserlingk, D. M. Weary, and K. A. Beauchemin. 2003b. Measuring the feeding behavior of lactating dairy cows in early to peak lactation. *J. Dairy Sci.* 86:3354-3361.
- DeVries, T. J., M. A. G. von Keyserlingk, and D. M. Weary. 2004. Effect of feeding space on the inter-cow distance, aggression, and feeding behavior of free-stall housed Holstein dairy cows *J. Dairy Sci.* 87:1432-1438.
- DeVries, T. J. and M. A. G. von Keyserlingk. 2005. Time of feed delivery affects the feeding and lying patterns of dairy cows. *J. Dairy Sci.* 88:625-631.
- Dhiman, T. R., M. S. Zaman, I. S. MacQueen, and R. L. Boman. 2002. Influence of corn processing and frequency of feeding on cow performance. *J. Dairy Sci.* 85:217-226.
- Endres, M. I., T. J. DeVries, M. A. G. von Keyserlingk, and D. M. Weary. 2005. Effect of feed barrier design on the behavior of loose-housed lactating dairy cows. *J. Dairy Sci.* 88:2377-2380.
- Fregonesi, J.A., C.B. Tucker, D.M. Weary, F.C. Flower, and T. Vittie. 2004. Effect of rubber flooring in front of the feed bunk on the behavior of dairy cattle. *J. Dairy Sci.* 87:1203-1207.
- French, N, and J. J. Kennelly. 1990. Effects of feeding frequency on ruminal parameters, plasma insulin, milk yield, and milk composition in Holstein cows. *J. Dairy Sci.* 73:1857-1863.
- Gibson, J. P. 1984. The effects of frequency of feeding on milk production of dairy cattle: An analysis of published results. *Anim. Prod.* 38:181-189.
- Grant, R. J., and J. L. Albright. 2000. Feeding Behaviour. Pages 365-382 in *Farm Animal Metabolism and Nutrition*. J. P. F. D'Mello, ed. CABI Publishing, Wallingford, Oxon, UK.

- Jeziarski, T. A., and M. Podluzny. 1984. A quantitative analysis of social behaviour of different crossbreds of dairy cattle kept in loose housing and its relationship to productivity. *Appl. Anim. Beh. Sci.* 13:31-40.
- Kononoff, P. J., and A. J. Heinrichs. 2003. The effect of corn silage particle size and cottonseed hulls on cows in early lactation. *J. Dairy Sci.* 86:2438-2451.
- Kononoff, P. J., A. J. Heinrichs, and H. A. Lehman. 2003. The effect of corn silage particle size on eating behavior, chewing activities, and rumen fermentation in lactating dairy cows. *J. Dairy Sci.* 86:3343-3353.
- Leonardi, C., and L. E. Armentano. 2003. Effect of quantity, quality, and length of alfalfa hay on selective consumption by dairy cows. *J. Dairy Sci.* 86:557-564.
- Leonardi, C., F. Giannico, and L. E. Armentano. 2005. Effect of water addition on selective consumption (sorting) of dry diets by dairy cattle. *J. Dairy Sci.* 88:1043-1049.
- Miller, K., and D. G. M. Wood-Gush. 1991. Some effects of housing on the social behaviour of dairy cows. *Anim. Prod.* 53:271-278.
- National Research Council. 2001. Nutrient requirements for dairy cattle. *Natl. Acad. Sci.* Washington, DC.
- Nocek, J. E., and D. G. Braund. 1985. Effect of feeding frequency on diurnal dry matter and water consumption, liquid dilution rate, and milk yield in first lactation. *J. Dairy Sci.* 68:2238-2247.
- Onetti, S. G., S. M. Reynal, and R. R. Grummer. 2004. Effect of alfalfa forage preservation method and particle length on performance of dairy cows fed corn silage-based diets and tallow. *J. Dairy Sci.* 87:652-664.
- Phillips, C. J. C., and M. I. Rind. 2001. The effects of frequency of feeding a total mixed ration on the production and behavior of dairy cows. *J. Dairy Sci.* 84:1979-1987.
- SAS Institute Inc. 1999. *SAS User's Guide*. SAS Institute Inc., Cary, NC.
- Shabi, Z., I. Bruckental, S. Zamwell, H. Tagari, and A. Arieli. 1999. Effects of extrusion of grain and feeding frequency on rumen fermentation, nutrient digestibility, and milk yield and composition in dairy cows. *J. Dairy Sci.* 82: 1252-1260.
- Shabi, Z., M. R. Murphy, and U. Moallem. 2005. Within-day feeding behavior of lactating dairy cows measured using a real-time control system. *J. Dairy Sci.* 88:1848-1854.
- Shaver, R. D. 2002. Rumen acidosis in dairy cattle: Bunk management considerations. *Advances in Dairy Technology.* 14:241-249. University of Alberta, Edmonton, Alberta, Canada.

Stone, W. C. 2004. Nutritional approaches to minimize subacute ruminal acidosis and laminitis in dairy cattle. *J. Dairy Sci.* 87: E13-E26.

Van Soest, P. J., J. B. Robertson, and B. A. Lewis. 1991. Methods for dietary fiber, neutral detergent fiber and non-starch polysaccharide in relation to animal nutrition. *J. Dairy Sci.* 74:3583–3597.

CHAPTER 5: Effect of feeding space on the inter-cow distance, aggression, and feeding behavior of free-stall housed lactating dairy cows^{4?}

5.1 INTRODUCTION

Dairy cows in North America are commonly housed in free-stall barns with approximately 0.6 m of feed bunk space/ cow (Grant and Albright, 2001). Research on feed bunk space has concluded that cows can be kept with as little as 0.2 m of feed bunk space/cow without adversely affecting DMI or milk production (e.g. Friend et al., 1977; Collis et al., 1980). However, increased animal densities are linked to reduced inter-individual distances and increased aggressive behavior (Keeling and Duncan, 1989; Kondo et al., 1989), perhaps limiting the ability of some cows to feed.

Under extensive grazing systems, cattle will often synchronize their behavior; that is, many animals in the group will feed, ruminate, and rest at the same times (Miller and Wood-Gush, 1991; Rook and Huckle, 1995). Studies have shown, however, that the synchronization of behaviors is reduced when cattle are housed intensively indoors (O'Connell et al. 1989; Miller and Wood-Gush, 1991), perhaps because of competition for space or resources. For example, Friend and Polan (1974) reported that only 66% of cows could eat at one time when provided with 0.5 m of feed bunk space and recent work by our group has found that when given 0.6 m of feed bunk space/cow, less than 70% of animals feed simultaneously (DeVries et al., 2003a). These findings suggest that space availability limits animals from feeding together, particularly during popular eating times. If feed bunk space is limited, increased competition among cows at the feeder may lead to some cows modifying their feeding times to avoid aggressive interactions (Miller and Wood-Gush, 1991). In this case, subordinate cows would likely be most limited in

⁴A version of this chapter has been published. DeVries, T. J., M. A. G. von Keyserlingk, and D. M. Weary. 2004. Effect of feeding space on the inter-cow distance, aggression, and feeding behavior of free-stall housed lactating dairy cows. *J. Dairy Sci.* 87:1432-1438.

their access to feed during peak-feeding times (Friend and Polan, 1974). It has also been suggested that increased feeding competition may reduce intake and increase feeding rate, possibly increasing the risk for metabolic problems such as left displaced abomasums and sub-acute ruminal acidosis (Shaver, 1997; 2002).

The objectives of the current study were to determine if doubling the amount of feed bunk space from 0.5 to 1.0 m per animal leads to more space between cows at the feeder and fewer aggressive social interactions among cows, ultimately allowing cows to increase their feeding activity, particularly at peak-feeding times. In addition, we evaluated whether subordinate cows are more affected by space availability.

5.2 MATERIALS AND METHODS

5.2.1 Animals, Housing, and Diet

Two primiparous and 22 multiparous (parity = 2.95 ± 1.25 ; mean \pm SD) lactating Holstein dairy cows were used in the study. The animals were 85.3 ± 7.0 DIM at the beginning of the data collection period and had an average milk yield of 40.3 ± 3.0 kg/d over the course of the experiment. The cows were housed in a free-stall barn located at The University of British Columbia Dairy Education and Research Centre (Agassiz, BC, Canada) and were managed according to the guidelines set by the Canadian Council on Animal Care (1993). The cows were fed a TMR consisting of 30% corn silage, 8% grass silage, 4% alfalfa hay, 5% 3rd cut grass hay, 16% steam-rolled corn, and 37% concentrate mash on a DM basis. The TMR was formulated according to the NRC (2001) nutrient requirement recommendations for high producing dairy cows. Cows were fed from a feed bunk with access via a pendulous feed rail. Animals were fed

daily at approximately 0600 h and 1600 h and were milked at approximately 0700 h and 1700 h daily. Feed was pushed up closer to the cows at 1100 h and 2200 h daily.

5.2.2 Experimental Treatments and Design

The 24 lactating cows were used in a 2 x 2 cross-over design replicated over time. The animals were divided into 4 equal groups of 6 cows, which were balanced according to projected 305 d milk production ($12,645 \pm 1486$ kg; mean \pm SD), average DIM (85.3 ± 7.0), and average parity. Experimental treatments consisted of either 0.5 or 1.0 m of feed bunk space per animal. The 0.5 m treatment approximated the minimum standard typically recommended (Grant and Albright, 2001). The 1.0 m treatment was selected to provide a contrast within a range that is still relevant to producers.

Two adjacent pens, each having a total of 6 m of accessible feed bunk space and 12 free stalls filled with 40 cm of washed river sand, were used in the study. In each pen, the 12 stalls were configured in 3 rows. Two rows faced one another, were open at the front ('head-to-head'), and had a stall length of 240 cm. Two of these stalls were chained off to prevent access by cows, as was the entire back row of 4 stalls, such that 6 stalls were available for each group of 6 cows.

At the start of the first replication, one group had access to 0.5 m of feed bunk space/cow and the adjacent group had 1.0 m of feed bunk space/cow. The 0.5 m of feed bunk space/cow was achieved by placing a concrete partition (60 cm x 60 cm x 90 cm) midway along the feed bunk. When this partition was in place, feed was placed only on the half of the feed bunk furthest from the adjacent pen with 1.0 m of feed bunk space/cow. Each group was fed at the same time, and feed was evenly distributed along the available feed bunk space.

Groups were exposed to each treatment for a 2-d adjustment period followed by 7 d of data collection. The feed bunk space allowance was then switched for the 2 groups by moving the concrete partition from the feed bunk of the one pen to the feed bunk of the adjacent pen. Again, animals had a 2-d adjustment period followed by 7 d of observations on the new treatment. This same procedure was then repeated with the 2 remaining groups of cows.

5.2.3 Behavioral Recording

Distance between individuals, number of displacements, and feeding behavior of the cows at the feed bunk were recorded for 7 d per treatment. Spacing and aggressive behavior was monitored using time-lapse video equipment. The animals were videotaped using one video camera (Panasonic WV-BP330) per pen, a time-lapse videocassette recorder (Panasonic AG-6540) and a video multiplexer (Panasonic WJ-FS 216). The video cameras were located 6 m above the feed bunk, and red lights (100 W) were used to facilitate recording at night. Individual animals were identified with unique alphanumeric symbols made with hair dye (Clairol's Nice and Easy # 122, Natural Black, or Clairol's L'image Maxiblonde, depending on hair color) on the back. Feeding behavior was monitored for the entire experiment using an electronic feed bunk monitoring system (GrowSafe Systems Ltd., Airdrie, AB, Canada) that recorded individual cow presence (hits: a reading that occurs every 6 s for the duration of time the cow is standing at the feed bunk) at the feed bunk. This system has previously been described (DeVries et al., 2003b) and validated (see Appendix 1: DeVries et al., 2003c).

Inter-cow distances and aggressive displacements at the feed bunk were recorded during the 90-min period following the twice-daily provision of fresh feed. Feed was either provided when the cows were gone for milking or just prior to milking. The appearance of the first cow

feeding on the fresh feed marked the beginning of these 90-min observation periods. In cases where feed was available prior to milking, observations began after the feed was initially provided but were suspended during milking and then resumed once the first animal had returned from the parlor and started to feed. This 90-min post-feeding (PF) period has previously been identified as the time when the largest concentrations of cows are present at the feed bunk (DeVries et al., 2003a).

5.2.3.1 Measuring inter-cow distance and aggressive displacements. To ensure a common reference point when measuring inter-cow distances, a cross made of reflective tape was glued onto the third thoracic vertebra of each animal, identified by palpation from the left lateral side of each cow. The feed rail of both pens was marked with a permanent vertical line every 0.3 m on center. The cow's position was recorded by matching the reflective cross on the animal to the reference points on the neck rail, with the precision of one-half spacing between points (0.15 m). Observations of inter-cow distances and the number of animals present at the feed bunk were made every 5 min for the 90-min PF period for each day of data collection.

Displacements from the feed bunk within the 90-min PF period were also recorded. A displacement was noted when a butt or a push from the actor (instigator) resulted in the complete withdrawal of the reactor's head from beneath the feed rail. In addition to using the number of displacements as a dependent variable, these observations were also used to calculate an index of success in agonistic interactions for each individual cow. This index was calculated using the methods described by Mendl et al. (1992). Displacement data were combined from both treatments. The index of success was calculated as follows:

$$\frac{\text{number of cows that an individual is able to displace}}{\text{number of cows that an individual is able to displace} + \text{number of cows that are able to displace the individual}} \times 100\%$$

5.2.3.2 Measuring feeding behavior. The feeding behavior of individual cows was quantified using measures of daily feeding activity (hits/d), feeding intensity (hits/meal min), and total daily mealtime (min/d), using the methods described by DeVries et al. (2003b). Estimates of mealtime rely on the use of a meal criterion, which is the minimum time interval between visits to the feed bunk to consider the next feed bunk visit as being part of a new meal. Therefore, a pooled meal criterion (26.41 min) was calculated using the data from all 24 cows according to the methods described by DeVries et al. (2003b). All 3 measures, feeding activity, feeding intensity, and total daily mealtime were calculated for each cow for each treatment day. Feeding activity was also calculated for the 90-min PF periods for each cow for each treatment day.

5.2.4 Data Analyses

For the analyses of inter-cow distances, displacements from the feed bunk, and feeding behavior, the pen was considered as the experimental unit, with measures from multiple days and cows averaged to create one observation per pen per treatment. Inter-cow distances were further averaged for the number of cows that were present at the feed bunk when each measurement was taken. There was a significant interaction between treatment and number of animals present at the feed bunk for the inter-cow distance measurements; consequently, these data were analyzed separately for each number of animals present. Treatment effects on the inter-cow distances, number of displacements, and feeding behavior measures were tested by one-sample paired *t*-tests with 3 degrees of freedom.

Overall, treatment responses were tested using the pen as the experimental unit; however, we had a specific prediction that certain cows would respond differently in their PF feeding

activity (feeding activity during the 90 min after provision of fresh feed) to the 1.0 m treatment. Therefore, we used two within-cow methods to ascertain which cows had the greatest response in their PF feeding activity to the 1.0 m of feed bunk space. First, this measure was analyzed using the regression procedure of SAS (1985). The PF feeding activity of the cows with 1.0 m of feed bunk space were regressed against the PF feeding activity with 0.5 m of feed bunk space. To determine if cows changed on average, the intercept was tested for difference from zero, and to determine the extent of the change relative to the initial value, the slope was tested for difference from one. Secondly the effect of treatment on PF feeding activity was evaluated using an analysis of covariance (SAS 1985), using each cow's index of success as a covariate. The model tested the terms for index of success (1 df), cows (22 df), treatment (1 df), and the interaction between treatment and index of success (1 df) against the residual error (22 df).

5.3 RESULTS

5.3.1 Inter-cow Distance

The distance between neighboring cows ranged from 0.15 to 2.10 m for 0.5 m of feed bunk space and from 0.30 to 4.20 m for 1.0 m of feed bunk space. There was a significant interaction ($P < 0.001$) between the number of animals present at the feed bunk and the average distance between animals. Therefore, the effect of feed bunk space on the distance between neighboring cows was analyzed separately for each density (Table 5.1). Regardless of the number of animals present at the feed bunk, the average distance between cows was at least 60% greater at 1.0 m of feed space/cow relative to the 0.5 m treatment. The smallest range in distance between neighbouring cows (0.30 to 0.60 m) was seen with 6 animals feeding with 0.5 m of feed

bunk space/cow. The largest range in distance between neighbouring cows (0.60 to 4.20 m) was seen with 2 animals feeding with 1.0 m of feed bunk space/cow.

5.3.2 Displacements

The frequency of displacements per 90-min PF period, as measured by the number of times a cow physically displaced another from the feed bunk, was higher ($P < 0.05$) when animals had access to 0.5 m of feed bunk space/cow (1.55 ± 0.17 ; mean \pm SE) than with 1.0 m of feed bunk space (0.66 ± 0.17).

5.3.3 Feeding Behavior

Feeding activity was 14% higher, and total daily mealtime was 10% higher when cows were provided the 1.0 m treatment compared to 0.5 m treatment (Table 5.2). These differences in feeding behavior between treatments were particularly pronounced at peak feeding times: feeding activity during the 90-min PF period increased by 24% when cows were provided with more feed bunk space. This is further evidenced in Figure 5.1 where we see more animals at the feed bunk with 1.0 m of feed bunk space during the time period immediately following the provision of fresh feed and return from milking.

Since there was a significant increase in PF feeding activity with more feed bunk space, we used linear regression to determine how the individual cows responded to the treatment (Figure 5.2). The coefficient of determination was statistically significant ($P < 0.01$). The intercept (158.90 ± 29.76 ; mean \pm SE) was greater than zero ($P < 0.001$). Additionally, the cows with lower PF feeding activity when they had access to 0.5 m of feed bunk space showed greater increases with increased feed bunk space, as indicated by the slope (0.48 ± 0.13) for this linear

relationship being significantly less than one ($P < 0.001$). Analysis of covariance demonstrated an interaction between response to treatment and index of success for PF feeding activity ($P < 0.001$). Those cows with a low index of success had greater increases in PF feeding activity when provided with more feed bunk space than those cows with a high index of success. Indeed, 31% of the variation in the individual change in PF feeding activity was explained by the individual's index of success ($P < 0.001$).

5.4 DISCUSSION

When provided with more space at the feeder, cows increased distances from their nearest neighbor, reduced their frequency of aggressive interactions, and increased feeding activity. There has been some previous research with other farm animals indicating that the distance between neighboring animals is dependent on the amount of space they are provided (Keeling and Duncan, 1989; Keeling, 1994; Sibbald et al., 2000). The one previous study of this type using dairy cattle also found that the distance to the nearest neighbor increased with increased floor space allowance (Kondo et al., 1989). In the current study, we found that increased space at the feeder increased spacing between cows regardless of the number of cows present at the feed bunk.

We also found that the range in inter-cow distances was greater when fewer animals were present at the feed bunk, particularly with 1.0 m of feed bunk space. In a study on grazing sheep, Sibbald et al. (2000) found the highest range in nearest neighbor distances between grazing sheep was at the highest levels of space allowance. At the highest densities, the size of the animal itself can create a lower limit to the space between two animals; as the amount of space provided at the feeder declines, nearest neighbor distances will tend to decline to the limit of average body

width. The hip width of Holstein dairy cows can exceed 0.5 m (Enevoldsen and Kristensen, 1997), and body width typically exceeds hip width. For this reason, the range in distance between cows when six cows were feeding with 0.5 m of feed bunk space was very small.

Not surprisingly, given the larger distances between cows, we also found a change in the level of aggressive behavior with more feed bunk space. The average number of times a cow displaced another from the feed bunk during the 90-min PF period when provided 1.0 m of feed bunk space/cow was only 43% of the level seen during that same time period for the 0.5 m treatment. This finding contrasts with Collis et al. (1980), who reported no change in the amount of aggressive behavior when feed bunk space was reduced from 1.05 to 0.45 m of feed bunk space. Unfortunately, these authors had very few observations, using only a single day of data for each treatment level, making the reliability of their results difficult to assess. Typically, studies involving feed bunk space have looked at the effects of increased competition due to reduced feed bunk space. Olofsson (1999) found that the number of displacements within a group increased when cows went from a stocking density of 1 to 4 cows per feeding station. However, the current study is the first to show that providing more feed bunk space than typically allocated can reduce aggression.

In the current study, cows increased feeding activity but not feeding intensity when given 1.0 m of feed bunk space compared to 0.5 m. This effect was particularly evident during the 90-min PF period, with cows increasing feeding activity by 24% when given access to the higher amount of feed bunk space. This increase accounted for over 54% of the increase in daily feeding activity when provided access to the 1.0 m treatment. These changes during the 90-min PF period were likely due to the increased spacing and decreased aggressive interactions: with more

room to feed and less social hindrance at 1.0 m of feed bunk space, cows had more opportunity and time to consume their feed.

Despite the significant increase in PF feeding activity, there was substantial between cow variation in this response. Cows that displayed the lowest PF feeding activity with 0.5 m of feed bunk space showed the greatest increase in PF feeding activity with 1.0 m of feed bunk space, and these cows also had the lowest index of success. Therefore, increasing feed bunk space to 1.0 m per cow allows subordinate cows to increase feeding activity at peak feeding times.

The present study is the first to demonstrate that feeding activity and total daily mealtime can be increased by providing more feed bunk space than typically used on dairy farms. Interestingly, previous studies (Friend et al., 1977; Collis et al., 1980) have indicated that feed bunk space can be reduced to as little as 0.2 m per cow without impairing DMI or total time spent eating. However, these earlier studies did not take into consideration the diurnal feeding pattern of cows, and how feeding patterns change under situations of restricted feed bunk space. With 0.2 m of feed bunk space, many cows may not be able to gain access to the feed at peak feeding times, forcing them to shift their feeding times to other parts of the day, including late at night (Forbes, 1995). Georgsson and Svendsen (2002) reported that small pigs housed in groups with larger animals shifted their feeding behavior when only one feeder was present; namely, they consumed a larger proportion of their daily feed intake during the night time hours when compared to having access to two feeders. Such a shift in feeding time may be problematic for cows, since sorting of the TMR can reduce the quality of the feed for those who do not have access at the time fresh food is provided (Leonardi and Armentano, 2003). The results of the present study indicate that providing more feed bunk space improves access to fresh feed, particularly for the subordinate cows, possibly reducing the variation in diet quality consumed by

the cows. It has also been suggested that increased feed access and reduced competition may increase feed intake and decrease feeding rate, possibly reducing the risk for metabolic problems such as sub-acute ruminal acidosis and left displaced abomasums (Shaver, 1997; Shaver, 2002).

5.5 CONCLUSIONS

Increasing the feed bunk space from 0.5 m to 1.0 m per cow allowed animals to space themselves further apart while feeding and reduce their frequency of aggressive interactions. These changes in spacing and aggressive behavior in turn allowed cows to increase feeding activity in the time after the provision of fresh feed. This increase in feeding activity was particularly true for those subordinate cows that had limited PF feeding activity with 0.5 m of feed bunk space. We therefore recommend increased feed bunk space over the current industry standard to increase feeding activity and reduce aggressive interactions in lactating dairy cows.

5.6 ACKNOWLEDGEMENTS

We thank the staff and students at The University of British Columbia's Dairy Education and Research Centre and the University's Animal Welfare Program. In particular we thank Sara Piper for her help with the video analysis and Cassandra Tucker for her helpful comments concerning the manuscript. We also thank Agriculture and Agri-Food Canada's Lethbridge Research Centre for the use of their feeding behavior monitoring system. Trevor DeVries was supported by a Natural Sciences and Engineering Research Council of Canada Postgraduate Scholarship. The project was funded by the Natural Sciences and Engineering Research Council of Canada, through the Industrial Research Chair in Animal Welfare, and by contributions from the Dairy Farmers of Canada, the Beef Cattle Industry Development Fund, the BC Dairy

Foundation, the BC SPCA, members of the BC Veterinary Medical Association, and many other donors listed on our website at <http://www.landfood.ubc.ca/animalwelfare>.

Table 5.1. The inter-cow distance¹ (m) with 0.5 m and 1.0 m of allocated feed bunk space/cow with varying numbers of cows present at the feed bunk. The SE and *P* values for the test of treatment are provided for each animal density.

Number of cows feeding	Feed bunk space/cow		SE	<i>P</i>
	0.5 m	1.0 m		
2	1.02	1.86	0.02	< 0.001
3	0.76	1.30	0.04	< 0.003
4	0.67	1.08	0.01	< 0.001
5	0.56	0.92	0.01	< 0.001
6	0.49	0.80	0.02	< 0.002

¹Distances were calculated from video recordings at 5 min scan samples of 90-min post-feeding periods and were averaged for 7 d per treatment for 4 groups of cows (6 cows per group), fed twice a day.

Table 5.2. Measures of feeding behavior¹ with 0.5 m and 1.0 m of allocated feed bunk space/cow. The least-square SE and *P* values for the test of treatment are provided.

Measures	Feed bunk space/cow		SE	<i>P</i>
	0.5 m	1.0 m		
Daily feeding activity ²	1334.5	1520.9	24.51	< 0.001
Total daily mealtime ³	279.0	307.6	4.26	< 0.001
Feeding intensity ⁴	4.87	4.97	0.09	0.46
Post-feeding feeding activity ⁵	210.2	260.7	11.18	0.004

¹Data were averaged for 7 d per treatment for 4 groups of cows (6 cows per group), fed twice a day.

²The total number of hits that the feed bunk monitoring system recorded per day.

³Sum total length of time (min) included in the meals per day.

⁴The number of hits per day divided by the total daily mealtime.

⁵Feeding activity during the 90 min following provision of fresh feed.

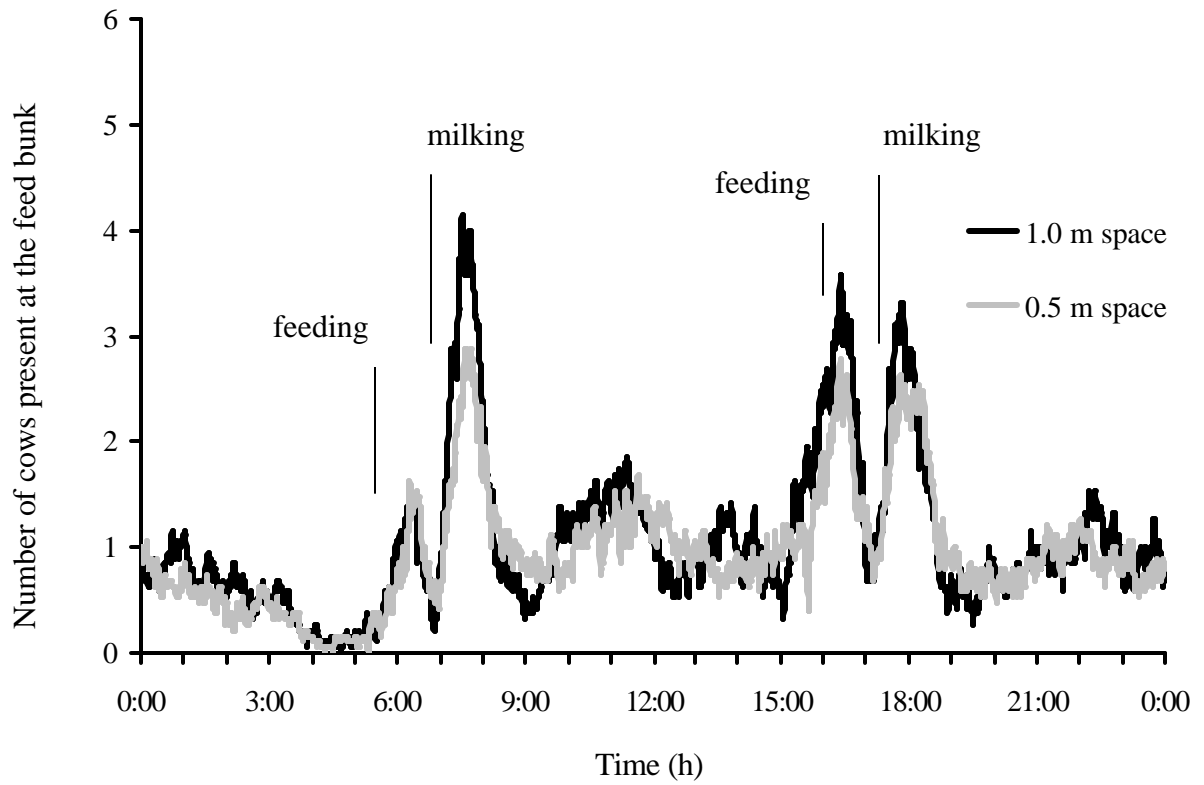

Figure 5.1. Number of cows per group present at the feed bunk over a 24-h period (number for each 60-s interval during the day) for both 0.5 m and 1.0 m feed bunk space/cow treatments. Data are averaged for 7 d per treatment for 4 groups, each containing 6 cows.

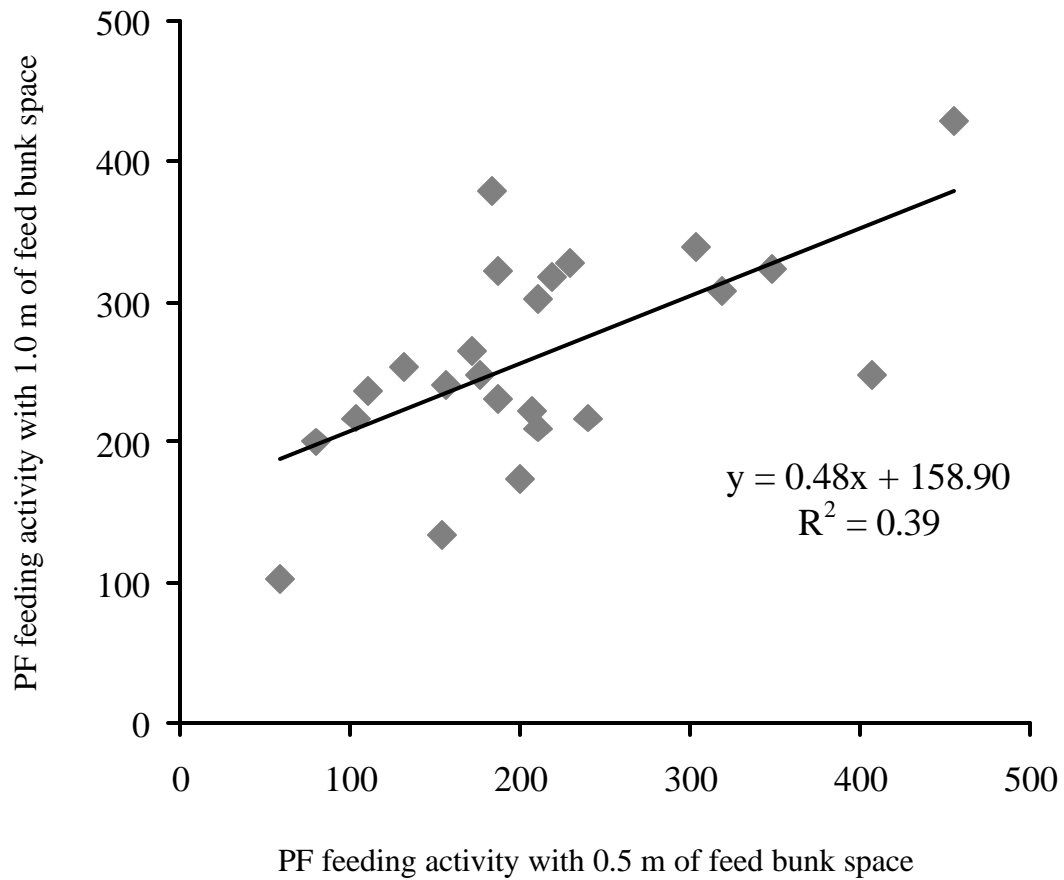

Figure 5.2. The relationship of post-feeding (PF) feeding activity (hits per 90-min PF period) measured on dairy cows with 0.5 m of feed bunk space/cow and with 1.0 m of feed bunk space/cow. PF feeding activity was averaged for 7 d per treatment for 24 cows (4 groups of 6), fed twice a day.

5.7 REFERENCES

- Canadian Council on Animal Care. 1993. Guide to the care and use of experimental animals. Vol. 1. E. D. Olfert, B. M. Cross, and A. A. McWilliam, ed. CCAC, Ottawa, Canada.
- Collis, K. A., M. J. Vagg, P. T. Gleed, C. M. Copp, and B. F. Sansom. 1980. The effects of reducing manger space on dairy cow behavior and production. *Vet. Rec.* 107:197-198.
- DeVries, T. J., M. A. G. von Keyserlingk, and K. A. Beauchemin. 2003a. Diurnal feeding pattern of lactating dairy cows. *J. Dairy Sci.* 86:4079-4082
- DeVries, T. J., M. A. G. von Keyserlingk, D. M. Weary, and K. A. Beauchemin. 2003b. Measuring the feeding behavior of lactating dairy cows in early to peak lactation. *J. Dairy Sci.* 86:3354-3361.
- DeVries, T. J., M. A. G. von Keyserlingk, D. M. Weary, and K. A. Beauchemin. 2003c. Validation of a system for monitoring feeding behavior of dairy cows. *J. Dairy Sci.* 86:3571-3574.
- Enevoldsen, C., and T. Kristensen. 1997. Estimation of body weight from body size measurements and body condition scores in dairy cows. *J. Dairy Sci.* 80:1988-1995.
- Forbes, J. M. 1995. *Voluntary Food Intake and Diet Selection in Farm Animals*. CAB Int., Wallingford, United Kingdom.
- Friend, T. H., and C. E. Polan. 1974. Social rank, feeding behavior, and free stall utilization by dairy cattle. *J. Dairy Sci.* 57:1214-1220.
- Friend, T. H., C. E. Polan, and M. L. McGilliard. 1977. Free stall and feed bunk requirements relative to behavior, production and individual feed intake in dairy cows. *J. Dairy Sci.* 60:108-116.
- Georgsson, L., and J. Svendsen. 2002. Degree of competition at feeding differentially affects behavior and performance of group-housed growing-finishing pigs of different relative weights. *J. Anim. Sci.* 80:376-383.
- Grant, R. J., and J. L. Albright. 2001. Effect of animal grouping on feeding behavior and intake of dairy cattle. *J. Dairy Sci.* 84 (E. Suppl.):E156-E163.
- Keeling, L. J., and I. J. H. Duncan. 1989. Inter-individual distances and orientation in laying hens housed in group of three in two different-sized enclosures. *Appl. Anim. Behav. Sci.* 24:325-342.
- Keeling, L. J. 1994. Inter-bird distances and behavioural priorities in laying hens: the effect of spatial restriction. *Appl. Anim. Behav. Sci.* 39:131-140.

- Kondo, S., J. Sekine, M. Okubo, and Y. Asahida. 1989. The effect of group size and space allowance on the agonistic spacing behaviour of cattle. *Appl. Anim. Behav. Sci.* 24:127-135.
- Leonardi, C., and L. E. Armentano. 2003. Effect of quantity, quality, and length of alfalfa hay on selective consumption by dairy cows. *J. Dairy Sci.* 86:557-564.
- Mendl, M., A. J. Zanella, and D. M. Broom. 1992. Physiological and reproductive correlates of behavioural strategies in female domestic pigs. *Anim. Behav.* 44:1107-1121.
- Miller, K., and D. G. M. Wood-Gush. 1991. Some effects of housing on the social behaviour of dairy cows. *Anim. Prod.* 53:271-278.
- National Research Council. 2001. Nutrient requirements for dairy cattle. *Natl. Acad. Sci. Washington, DC.*
- O'Connell, J., P. S. Giller, and W. Meaney. 1989. A comparison of dairy cattle behavioural patterns at pasture and during confinement. *Irish J. of Agric. Res.* 28:65-72.
- Olofsson, J. 1999. Competition for total mixed diets fed for ad libitum intake using one or four cows per feeding station. *J. Dairy Sci.* 82:69-79.
- Rook, A. J., and C. A. Huckle. 1995. Synchronization of ingestive behaviour by grazing dairy cows. *Anim. Beh.* 60:25-30.
- SAS User's Guide: Statistics, Version 5 Edition. 1985. SAS Inst., Inc., Cary, NC.
- Shaver, R. D. 1997. Nutritional risk factors in the etiology of left displaced abomasum in dairy cows: A review. *J. Dairy Sci.* 80:2449-2453.
- Shaver, R. D. 2002. Rumen acidosis in dairy cattle: Bunk management considerations. *Advances in Dairy Technology.* 14:241-249. University of Alberta, Edmonton, Alberta, Canada.
- Sibbald, A. M., L. J. F. Shellard, and T. S. Smart. 2000. Effects of space allowance on the grazing behaviour and spacing of sheep. *Appl. Anim. Behav. Sci.* 70:49-62.

CHAPTER 6: Feed stalls affect the social and feeding behavior of lactating dairy cows^{5?}

6.1 INTRODUCTION

In the dairy industry 0.6 m of linear feed bunk space has been traditionally regarded as an adequate amount space per lactating dairy cow (Grant and Albright, 2001). In previous research we examined the effect of feed bunk space on the spacing, competitive, and feeding behavior of dairy cows, and found that increasing the amount of feed bunk space above 0.6 m leads to increased spatial separation between cows and fewer aggressive interactions while feeding (DeVries et al., 2004). These changes in spacing and aggressive behavior allowed cows to increase feeding activity, and this effect was most dramatic for the subordinate animals. In a follow-up study, we demonstrated that decreased stocking density at the feed bunk reduces competition and increases feeding time, regardless of the type of feed barrier used (Huzzey et al., 2006).

Even though the additional feed bunk space in both of these experiments reduced competition at the feed bunk, it did not eliminate it, suggesting that there are additional factors contributing to this competition for food resources. Research undertaken with other domesticated species indicates that the configuration of feeding spaces can have profound effects on feeding competition. Several researchers (e.g. Baxter, 1986; Barnett, 1997; Andersen et al., 1999) have investigated the effects of different feed trough partitions on the aggressive behavior of pigs observed during feeding. Without exception these researchers found that partitions between adjacent feeding animals reduced aggression and displacements at the feed trough and that longer partitions resulted in greater reductions in aggressive behavior.

⁵A version of this chapter has been accepted for publication. DeVries, T. J., and M. A. G. von Keyserlingk. 2006. Feed stalls affect the social and feeding behavior of lactating dairy cows. *J. Dairy Sci.* in press.

In many modern dairy systems, dairy cattle are separated from their feed by a post-and-rail feed barrier, which allows the cows to move their head to and from the feed as well as from side to side. For cattle, that often displace one another while feeding by swinging and butting with the head, modifications to the barrier that restricts contact between the head of a cow and the head and/or body of an adjacent cow may be particularly effective in reducing competition. We have recently completed two studies (Endres et al., 2005; Huzzey et al., 2006) comparing the post-and-rail barrier to the headlock barrier. A headlock barrier provides limited division (a vertical bar) between the necks of adjacent cows. In both studies, the use of the headlock barrier significantly reduced the incidence of displacements at the feed bunk. Unfortunately, the use of the headlock did not completely eliminate aggressive behavior at the feed bunk, indicating that the neck division may not provide full protection.

Konggaard (1983) suggested that cows might feel more protected when a physical separation exists between conspecifics during feeding. To date there is limited data available comparing feed barrier designs in free stall facilities that provide a partition between adjacent animals while feeding at the feed bunk. Bouissou (1970) tested different partitions between dominant and subordinate cows at the feed trough to determine which type of partition allowed the subordinate cow to feed for the longest period of time. Bouissou found that partitions that separated the heads and those that separated the heads and body of the individuals significantly increased the feeding times of the subordinate cows. Unfortunately, this research was conducted using only pairs of animals, preventing the extrapolation of the results to larger and more socially complex groups. Further, the cows used by Bouissou were horned, which may explain why the head separations provided the greatest benefit in terms of increased feeding times.

In summary, there is a growing body of evidence suggesting that decreasing stocking density at the feed bunk will reduce competition and increase feed access. Further, researchers have demonstrated in pigs and cattle that providing partitions that separate the bodies of adjacent animals can have profound effects on reducing competition and allowing animals to feed for longer periods of time. Based on this, our first objective was to provide further evidence that increased bunk space reduces the frequency of aggressive behavior at the feed bunk and improves feed access. Our second objective was to determine if the addition of partitions (feed stalls) between adjacent cows provides additional protection while feeding, particularly for subordinate cows.

6.2 MATERIALS AND METHODS

6.2.1 Animals, Housing, and Diet

Nine primiparous and 15 multiparous (parity = 3.3 ± 1.1 ; mean \pm SD) lactating Holstein dairy cows were used in the study. The animals were 141.7 ± 16.4 DIM at the beginning of the data collection period. The cows were housed in a free-stall barn located at The University of British Columbia Dairy Education and Research Centre (Agassiz, BC, Canada) and were managed according to the guidelines set by the Canadian Council on Animal Care (1993). The cows were fed ad libitum a TMR consisting of 14.7% corn silage, 21.3% grass silage, 12.3% alfalfa hay, and 51.7% concentrate mash on a DM basis. The composition of the TMR was 47.1% DM and contained on a DM basis 18.2% CP, 35.2% NDF, 19.0% ADF, and 0.88% Ca, and 0.42% P. The TMR was formulated according to the NRC (2001) nutrient requirement recommendations for high producing dairy cows. Cows fed from a feed bunk with access via a post-and-rail feed barrier, which was the same as that described by Huzzey et al. (2006). Animals

were delivered feed at approximately 0630 and 1515 h each day. Feed was pushed up closer to the cows at 1100, 1830 and 2230 h daily. The animals were milked between 0615 and 0645 h in the a.m. and between 1615 and 1645 h in the p.m. Milk yields were automatically recorded at each milking.

Representative samples of the TMR were taken for each group at the time of each feed delivery and from the orts on d 5 and 10 of each treatment period. Dry matter content of the samples was determined by oven-drying at 60°C for 2 d. Dry matter intake for each group for each day on treatment was recorded by subtracting the DM weight of the orts from the DM weight of the delivered feed. The daily orts averaged 10.7 ± 4.7 (mean \pm SD) % of the delivered feed provided over the course of the experiment. This study was designed to test predictions concerning feeding and competitive behavior and was not designed to test DMI or milk production differences (due to the inability to measure individual DMI and relatively short treatment periods, respectively); therefore treatment differences for these later variables were not tested. The cows had an average DMI of 25.0 ± 1.3 kg/d and an average milk yield of 39.9 ± 7.7 kg/d over the course of the experiment.

6.2.2 Experimental Treatments and Design

The animals were divided into 3 equal groups of 8 cows, which were balanced according to DIM, projected 305 d milk production ($11,409.4 \pm 1874.4$ kg), and average parity (2.9 ± 1.6). These groups were created by blocking cows into groups of 3 cows (similar in parity, DIM, and projected 305 d milk production), and then randomly assigning the cows in these blocks to 1 of the 3 experimental groups.

The groups were randomly assigned to 1 of 3 adjacent pens, each having a total of 7.38 m of accessible feed bunk space. Wooden partitions were placed within the feed bunk between the groups to prevent cows from consuming food from adjacent feed bunks. Each experimental pen (width = 7.38 m and length = 13.50 m) contained 12 free stalls configured in 3 rows. Two rows faced one another, were open at the front ('head-to-head'), and had a bed length of 2.40 m. The third row of free stalls faced a cement wall, and these stalls were 0.30 m longer to allow more space for getting up and lying down. All free stalls measured 1.20 m wide center to center, and the neck rail was 1.14 m above the stall surface. Stalls were deep bedded with 0.40 m of sand. The flooring throughout the pens was grooved concrete. The width of the alley between the 4 stalls closest to the feed bunk and the feed bunk was 3.53 m. These 4 stalls closest to the feed bunk were chained off to prevent access by cows such that 8 stalls were available for each group of 8 cows. All groups were housed together for 2 wks to allow for social adaptation prior to the beginning of the experiment.

The treatments tested were: 1) 0.64 m of feed bunk space/cow, 2) 0.92 m of feed bunk space/cow, and 3) 0.87 m of feed bunk space/cow with feed stall partitions (Artex Fabricators Ltd., Langley, BC, Canada) separating adjacent cows (see Figure 6.1), referred to from here on as 'feed stalls'. For the 0.64 m/cow treatment, feed bunk space was adjusted by placing 2 concrete partitions (one measuring 76 cm x 76 cm x 76 cm [width x length x height] and the other measuring 74 cm x 150 cm x 79 cm) in the left side of the feed bunk. For the feed stall treatment, 7 feed stall partitions were attached to the post-and-rail feed barrier and were spaced such that 0.87 m of linear bunk space was available for each cow within each stall. Each group was tested within their respective pens with each feed bunk configuration in 3 successive 10-d

treatment periods that were assigned to groups using a 3 x 3 Latin square design. The treatment periods included 3 d of treatment adaptation and 7 d of data collection.

6.2.3 Behavioral Recording

All behaviors were monitored using one video camera (Panasonic WV-BP330; Osaka, Japan) located 6 m above the feed bunk of each pen, a time-lapse videocassette recorder (Panasonic AG-6540) and a video multiplexer (Panasonic WJ-FS 216). Red lights (100 W) were used to facilitate recording at night. Individual cows were identified with unique alphanumeric symbols made with hair dye (Clairol's Nice and Easy # 122, Natural Black, or Clairol's Herbal Essences Bleach Blonde, depending on hair color; Stamford, Connecticut) on the back of the cows. The aggressive behavior of the cows was measured from continuous recordings of the last 4 d of each treatment period, while the feeding and standing behavior of the cows were recorded continuously for the last 7 d of each treatment period.

6.2.3.1 Measuring aggressive behavior. Social interactions (displacements from the feed bunk) were noted when an aggressive action (a butt or a push) from one cow (actor) resulted in the complete withdrawal of another cow's (reactor) head from beneath the feed rail (DeVries et al., 2004). Displacements were differentiated depending on where the actor initiated contact with the reactor's body: the front (head and neck), the side (area between the withers and hips), and the rear (area caudal from the hips).

In addition to using the number of displacements as a dependent variable, these observations were also used to calculate an index of success in competitive interactions for each individual cow. For this calculation, the data were combined from all treatments to create one index per cow. The index of success (Mendl et al., 1992; DeVries et al., 2004) was calculated as

follows:

$$\frac{\text{number of cows that an individual is able to displace}}{\text{number of cows that an individual is able to displace} + \text{number of cows that are able to displace the individual}} \times 100\%$$

6.2.3.2 Measuring feeding and standing behavior. The feeding behavior of individual cows, as well as the duration of inactive standing in the feed area, was scored from the video recordings using 10 min time sampling. For each scan, an animal was recorded as feeding when its head was completely past the feed rail and over the feed. A cow was recorded as inactively standing if it had all 4 feet within the alley closest to the feed bunk and was not feeding. Total time spent feeding and inactive standing were calculated by multiplying the number of scans by 10 (Endres et al., 2005; Huzzey et al., 2006). Both time spent feeding and time spent inactively standing were calculated for each cow for each treatment day. Additionally, to detect changes in the daily pattern of feed bunk attendance, these scans were used to calculate the percentage of the cows feeding and inactively standing over the course of a 24-h day. We also calculated and averaged the percentage of cows present at the feed bunk and inactively standing during the 90-min period following the delivery of feed when feeding activity was highest.

6.2.4 Data Analyses

For the analyses of feeding, standing, and aggressive behavior, the pen was considered as the experimental unit, with measures from multiple days and cows averaged to create one observation per pen per treatment. There was an interaction between treatment and the time of feeding (i.e. a.m. or p.m.) for the percentage of cows feeding and inactively standing during the 90-min period following the delivery of feed; consequently, these data were summarized and

analyzed separately for each time of feed delivery. Treatment effects were analyzed as a 3 x 3 Latin square with repeated measures using the PROC MIXED procedure of SAS (1999). The model included the fixed effect of treatment, the random effects of period and pen, and the residual error. Compound symmetry was selected as the covariance structure on the basis of best fit. To test the effects of increased feed bunk space, and meet our first objective, the means of the 0.64 m/cow treatment were contrasted against those of the 0.92 m/cow treatment. To test the effects of the feed stalls, and meet our second objective, we contrasted the means of the feed stall treatment to those of the 0.92 m/cow treatment, which was the same amount of linear bunk space but in an open feeding design (without feed stall partitions).

To test the hypothesis that socially subordinate cows would be most affected by the treatments, the effects of feed bunk space and feed stalls on the incidence of displacements from the feed bunk were also evaluated with cow as the observational unit and the cows' index of success as a covariate. These data were again analyzed as a 3 x 3 Latin square with repeated measures using the PROC MIXED procedure of SAS (1999). The model included the index of success as a covariate, the fixed effect of treatment, the interaction between index of success and treatment, the random effects of period and cow, and the residual error.

6.3 RESULTS

6.3.1 Aggressive Behavior

The frequency by which cows were displaced from the feed bunk was significantly reduced when there was 0.92 m of feed bunk space/cow compared to when there was 0.64 m of feed bunk space/cow (Table 6.1). This number was further reduced when the cows were provided with the feed stalls (0.87 m/cow plus feed stalls). Increased feed bunk space and

addition of the feed stalls also changed the method by which cows displaced others from the feed bunk. When cows were each provided 0.64 m of linear bunk space, significantly more displacements were initiated by the actor on the front and side of the reactor compared to when they had 0.92 m of bunk space. There was a further reduction in these types of displacements when the cows were fed using the feed stalls. Although there were significantly fewer displacements observed when cows were fed using the feed stalls, a greater proportion of those that did occur were initiated by the actor contacting the rear of the reactor when compared to the cows provided with 0.92 m of bunk space.

The cow-based analysis, considering the cows' index of success, revealed an index of success \times treatment interaction ($P < 0.001$), demonstrating that cows with lower indices of success had the greatest decrease in the number of times they were displaced per day when they were provided with either 0.92 m/cow of feed bunk space and with the feed stalls.

6.3.2 Feeding Behavior

Daily feeding time of the cows was higher when they were provided with 0.92 m of feed bunk space/cow compared to when they had 0.64 m of bunk space/cow (Table 6.2). Further, there was a tendency for daily feeding time to be higher when the cows had the feed stalls compared to when they had 0.92 m of open bunk space. Feed bunk attendance patterns of the cows (Figure 6.2) were influenced when more bunk space was provided and with the addition of feed stalls. During the a.m. peak feeding period, there was no difference among treatments in the percentage of cows present at the feed bunk (Table 6.3). However, during the p.m. peak feeding period, there were a higher percentage of cows at the feed bunk when 0.92 m of bunk space was

provided compared to 0.64 m of bunk space. Further, there were more cows present at the feed bunk in the feed stalls during this period than when the cows were on the 0.92 m/cow treatment.

6.3.3 Standing Behavior

The daily time spent inactively standing by the cows was higher when 0.64 m of feed bunk space was provided compared to when there was 0.92 m of bunk space (Table 6.2). There was also a tendency for the inactive standing time to be lower when cows were fed using the feed stalls compared to when they had 0.92 m of bunk space. Similar to feeding behavior, the treatment effect of increased bunk space on the inactive standing times of cows was most pronounced during the times of peak feeding activity. During the a.m. peak feeding period, there was a tendency for more cows to be inactively standing when they had 0.64 m of feed bunk space compared to when they had 0.92 m (Table 6.3). Similarly, in the p.m. peak feeding period, a significantly higher percentage of cows were inactively standing when they had 0.64 m of feed bunk space compared to when they had 0.92 m of bunk space. During this p.m. period, there was also a tendency for a lower percentage of cows to be inactively standing when they had the feed stalls compared to when they had 0.92 m of bunk space.

6.4 DISCUSSION

The results of the present study provide additional support to our previous conclusions that lactating dairy cows experience less competition and improved access to feed when provided with more than the industry standard of 0.6 m of feed bunk space per animal (DeVries et al, 2004; Huzzey et al., 2006). In this study, increasing the space availability at the feed bunk decreased the number of aggressive interactions at the bunk. The average number of times a cow

was displaced from the feed bunk when provided with 0.92 m/cow was only 57% of the level seen for the 0.64 m treatment (Table 6.1). This result agrees with previous findings of our research group. DeVries et al. (2004) reported that the average number of times a cow displaced another from the feed bunk during peak feeding periods, when provided 1.0 m/cow, was only 43% of the level seen during that same time period for a 0.5 m/cow treatment. Similarly, in the dose-response study by Huzzey et al. (2006) the average number of times a cow was displaced from the feed bunk when provided 0.81 m of feed bunk space/cow was less than the level seen for the 0.61 m treatment. A similar effect of feeding space has also been noted in pigs: Baxter (1986) demonstrated that pigs provided with more feeding space tended to be less aggressive while feeding.

The results indicated that the displacements that occurred during the 0.64 and 0.92 m/cow treatments were similar in type. When provided either 0.64 or 0.92 m of bunk space/cow, the majority of the displacements were initiated by physical contact occurring at either the front or side of the reactor. This observation indicates that cows were employing the same strategy when displacing other cows from the feed bunk, but decreased the frequency of this behavior when provided with more space.

In the present study we also observed that when feed bunk space was increased from 0.64 to 0.92 m/cow, daily feeding time increased by 4.6% (Table 6.2). This result is in agreement with our previous findings. In the study by Huzzey et al. (2006), we noted that a moderate increase in feed bunk space (from 0.61 to 0.81 m/cow) resulted in a 1.2% increase in daily feeding time. Similarly, when we doubled the amount of feed bunk space from 0.5 to 1.0 m/cow in DeVries et al. (2004), the daily feeding time of the cows increased by 14%. The results of the present study combined with those from our previous studies indicate that lactating dairy cattle appear to

realize greater benefits in terms of increased time spent feeding when provided with increasing amounts of available feeding space.

In the current study, cows spent 23 min longer per day standing in the feeding area while not feeding (inactive standing) when they had 0.64 m of feed bunk space compared to when they had 0.92 m of bunk space (Table 6.2). Increased inactive standing time in response to increased stocking density at the feeding area has been previously reported (Olofsson; 1999; Huzzey et al, 2006). As we suggested in Huzzey et al. (2006), this behavior may have long-term negative hoof health effects; however, more research is needed to establish the relationship between stocking density, standing behavior and hoof health. Similarly to the findings we reported in Huzzey et al. (2006), we found that the greatest differences in inactive standing occurred during the periods of peak feeding activity. This is likely due to the fact that cows are highly motivated to access freshly delivered feed (DeVries and von Keyserlingk, 2005) and in situations where feed space is limited due to high occupancy, some cows are forced to stand and wait for an available feeding spot. This may have unintended nutritional consequences for those cows that do not have access to feed at the time of delivery. Sorting of the TMR can reduce the quality of the feed, particularly in the later hours past the time of feed delivery (DeVries et al., 2005). Therefore, in situations where high stocking densities at the feed bunk force some cows to wait for access while others occupy the feed bunk, those waiting may end up consuming a ration that is not balanced to meet their nutritional requirements.

The second objective of this study was to determine if the addition of feed stalls would provide additional protection to the cows while feeding, particularly for subordinate cows. To our knowledge this is the first study to determine the effects of feed stalls on the aggressive behavior of group-housed lactating dairy cows. The addition of the feed stalls greatly decreased

the number of aggressive interactions at the feed bunk (Table 6.1). The average number of times a cow was displaced from the feed bunk, which had feed stalls, was only 45.5% of the level seen for the 0.92 m treatment. There have been several researchers who have investigated the effects of different feed trough partitions on the level of aggressive behavior of pigs exhibited during feeding (Baxter, 1986; Barnett, 1997; Andersen et al., 1999). Similar to our findings, all of these researchers found that partitions reduced the level of aggressive behavior at the feed trough. Interestingly, these researchers all noted that the longer the partitions were, the greater the decrease in aggressive behavior.

In some of our previous work (Endres et al., 2005; Huzzey et al., 2006) we compared the post-and-rail feed barrier to the headlock feed barrier. In these studies, the use of the headlock barrier significantly reduced the incidence of aggressive displacements at the feed bunk, regardless of stocking density at the feed bunk. In Huzzey et al. (2006), we hypothesized that this reduction in aggressive behavior may be attributed to cattle having more difficulty swinging their head from side to side while competing for the food resource when fed using the headlock barrier, which provides a physical barrier (a vertical bar) between the necks of the cows.

In the present study the dramatic decline in the number of displacements when cows were fed using the feed stalls may be explained by the design of the feed stall. The presence of the vertical bar at the front of the partition likely contributed to the 69% decrease in the number of displacements that stemmed from contact initiated at the front of the reactor (Table 6.1). The vertical bar likely minimized any attempts by the cows to swing their head from side to side in an attempt to displace another cow. The presence of the body partitions located between adjacent cows may have further contributed to the reduction in aggressive behavior. These partitions likely contributed to the 50% reduction in the number of displacements instigated at the side of

the reactor that occurred when cows had feed stalls compared to the 0.92 m of open bunk space.

Interestingly, when cows were allowed to access the TMR using the feeding stalls the strategy used by the actor to displace another cow changed dramatically, even though the amount of linear bunk space was similar between the 0.92 m/cow of open bunk space and the feed stall (0.87 m/cow) treatments. In contrast to the 0.92 treatment, the presence of the feed stalls resulted in more displacements being instigated by contact on the rear of the reactor by the actor (Table 6.1). In fact, 21.7% of the total daily displacements were instigated from the rear when the cows were provided with the feed stalls compared to only 0.9% of the total daily displacements instigated from the rear when cows were provided with 0.92 m/cow. It is interesting to note that despite the change in strategy used to displace others when the feed stalls were present, cows were not as effective in doing so, resulting in a decrease in total daily number of displacements.

The overall reduction in aggressive interactions at the feed bunk most likely contributed to the trend for increased daily time spent feeding by the cows when provided with feed stalls compared to just providing more space. This also agrees with the findings of Bouissou (1970), who found that partitions at the feeding area which separated the heads of adjacent animals and those which separated both the heads and bodies of side-by-side individuals allowed subordinate cows to feed for longer periods of time compared to when no division was used. A similar effect has also been shown in group-housed pregnant sows: time at the feed trough was found to increase with increasing length of partitions between feeding sows (Andersen et al., 1999). It is interesting to note that in Huzzey et al. (2006) we found that at a decreased stocking density (0.81 m per cow) cows spent more time feeding when using a post-and-rail versus a headlock feed barrier. In that study, we suggested that the post-and-rail provides less of a physical barrier between the cows and the feed, which may make feeding more comfortable for the cows. We

also suggested that cows may have developed a learned aversion to the headlocks due to their use in management practices that require cows to be restrained, possibly making cows reluctant to cross the barrier. The difference between our present findings and those in Huzzey et al. (2006) may be attributed to the design of the feed stalls. Even though the feed stalls contained a vertical bar between the necks of adjacent cows, similar to the headlock, the spatial separation between the vertical bars was much greater for the feed stalls used in our study. Unlike the headlock which is restrictive, the feed stall allows the cow to freely move her head while feeding. Additionally, the design of the feed stalls creates a defined feeding position for each cow and, as previously mentioned, dramatically reduces displacements from the feed bunk. Therefore, it seems likely that these factors make feeding more comfortable for the cows, allowing them to feed for longer periods of time.

These potential benefits in comfort while feeding may have contributed to the finding that the cows spent less time inactively standing in the feeding area when the feed stalls were present. This decrease in inactive standing was particularly noticeable during the peak-feeding period following the afternoon delivery of feed. During this time period there was a tendency for a lower percentage of cows to be inactively standing and an increase in the percentage of cows present at the feed bunk. No differences were noted for the a.m. period; however, this may be explained by the suggestion that lactating dairy cows do not show the same intensity in feeding activity in the a.m. compared to the p.m. (DeVries et al., 2003).

The cow-based analysis indicated that the subordinate cows received the most benefit from the increased feed bunk space and the addition of the feed stalls. In both comparisons, we noted that the subordinate cows experienced the greatest decrease in the number of times they were displaced per day. These results are similar to our findings in Huzzey et al. (2006), where

we reported that subordinate cows were displaced more often with the post-and-rail barrier design, particularly at high stocking densities. In the study by Andersen et al. (1999), lower ranked sows were subjected to less aggression and displacements as the length of the partitions increased. Thus, it appears that the additional feeding space, particularly when combined with feed stalls, improves the feeding conditions for those subordinate animals that may, under typical housing situations, have difficulty accessing feed at times when they have the greatest desire to feed. Therefore, decreasing stocking density at the feed bunk and the addition of feed stalls makes it easier for all cows to access fresh feed which, as previously mentioned, will act to reduce the between-cow variation in TMR consumed. This may be particularly important for early lactation cows, which often experience difficulty in meeting their nutritional requirements and succumb to disease. We, therefore, encourage further work examining the effects of reduced competition and improved feed access on the DMI, milk production, and health of lactating cows, particularly those in early lactation.

6.5 CONCLUSIONS

Increasing the feed bunk space from 0.64 to 0.92 m/cow resulted in a reduction in time spent standing in the feeding area while not feeding, a decrease in the frequency of aggressive interactions at the feed bunk and an increase in daily feeding time. Time spent standing in the feeding area while not feeding and aggressive interactions at the feed bunk were further reduced and feeding time was further increased by the addition of feed stalls. The feed stalls also forced cows to change the strategy by which they displaced others from the feed bunk, forcing them to initiate contact at the rear of the animal they were displacing rather than from the front and side as in the other two treatments. We also found that with the additional feeding space, particularly

when combined with feed stalls, those cows ranked lower in the social hierarchy at the feed bunk had the greatest decreases in the number of times they were displaced per day. Based on these results, we recommend decreasing the stocking density at the feed bunk and the use of feed stalls to improve feed access and reduce competition at the feed bunk, particularly for subordinate animals.

6.6 ACKNOWLEDGEMENTS

We thank the staff and students at The University of British Columbia's Dairy Education and Research Centre and the University's Animal Welfare Program. In particular we thank Kiyomi Ito for her help with the video analysis, Audrey Nadalin for her help with the feed sample drying, Dan Weary for his comments on the statistical design and analyses, and Julie Huzzey for her comments on the manuscript. Trevor DeVries was supported by a Natural Sciences and Engineering Research Council of Canada (NSERC) Canada Graduate Scholarship. This project was funded by NSERC, through the Industrial Research Chair in Animal Welfare, and by contributions from the Dairy Farmers of Canada, the British Columbia Dairy Foundation, the British Columbia SPCA, members of the British Columbia Veterinary Medical Association, and many other donors listed on the Animal Welfare website at <http://www.landfood.ubc.ca/animalwelfare>.

Table 6.1. Incidence of displacements from the feed bunk¹ and the point of initial contact that resulted in a displacement at the feed bunk with 0.64 m of feed bunk space/cow, 0.92 m of feed bunk space/cow, and feed stalls (0.87 m of bunk space/cow with feed stall partitions). The least-square SE and *P* values for the test of treatment are provided.

Variable	Treatment			SE	<i>P</i> ²	
	0.64 m	0.92 m	Feed stall		Space	Feed stall
Displacements, ³ no./cow/d	9.74	5.59	2.54	0.26	0.003	0.006
Front, ⁴ no./cow/d	6.47	4.08	1.26	0.21	0.009	0.006
Side, ⁵ no./cow/d	3.08	1.46	0.73	0.11	0.007	0.03
Rear, ⁶ no./cow/d	0.19	0.05	0.55	0.07	0.18	0.02

¹Data were averaged for 4 d per treatment for 3 groups of cows (8 cows per group).

²Probability for contrasts: space = 0.64 m vs. 0.92 m; feed stall = 0.92 m vs. feed stalls.

³Total number of displacements from the feed bunk per cow per day.

⁴Number of displacements per cow per day in which the actor made contact with the front (head and neck) of the reactor's body.

⁵Number of displacements per cow per day in which the actor made contact with the side (area between withers and hips) of the reactor's body.

⁶Number of displacements per cow per day in which the actor made contact with the rear (area caudal from the hips) of the reactor's body.

Table 6.2. Measures of feeding time and inactive standing behavior¹ with 0.64 m of feed bunk space/cow, 0.92 m of feed bunk space/cow, and feed stalls (0.87 m of bunk space/cow with feed stall partitions). The least-square SE and *P* values for the test of treatment are provided.

Variable	Treatment			SE	<i>P</i> ²	
	0.64 m	0.92 m	Feed stall		Space	Feed stall
Feeding time, ³ min/d	314.3	328.9	339.5	9.1	0.02	0.06
Inactive standing, ⁴ min/d	93.5	70.5	63.9	6.5	0.01	0.1

¹Data were averaged for 7 d per treatment for 3 groups of cows (8 cows per group).

²Probability for contrasts: space = 0.64 m vs. 0.92 m; feed stall = 0.92 m vs. feed stalls.

³Average feeding time/d per cow.

⁴Average time spent inactively standing/d per cow.

Table 6.3. Percentage¹ of cows per group at the feed bunk and inactively standing averaged over the period of peak feeding activity (90 min following the delivery of fresh feed) with 0.64 m of feed bunk space/cow, 0.92 m of feed bunk space/cow, and feed stalls (0.87 m of bunk space/cow with feed stall partitions). The least-square SE and *P* values for the test of treatment are provided.

Variable	Treatment			SE	<i>P</i> ²	
	0.64 m	0.92 m	Feed stall		Space	Feed stall
% of cows at the feed bunk in a.m. ³	70.1	70.8	73.5	4.7	0.8	0.35
% of cows at the feed bunk in p.m. ³	62.3	64.4	67.1	2.7	0.05	0.03
% of cows standing inactive in a.m. ⁴	7.2	3.8	3.8	0.9	0.08	0.95
% of cows standing inactive in p.m. ⁴	8.4	5.9	4.2	1.0	0.03	0.07

¹Data were averaged for 7 d per treatment for 3 groups of cows (8 cows per group).

²Probability for contrasts: space = 0.64 m vs. 0.92 m; feed stall = 0.92 m vs. feed stalls.

³ Percentage of cows per group at the feed bunk averaged over the period of peak feeding activity (90 min following the delivery of fresh feed).

⁴ Percentage of cows per group inactively standing averaged over the period of peak feeding activity (90 min following the delivery of fresh feed).

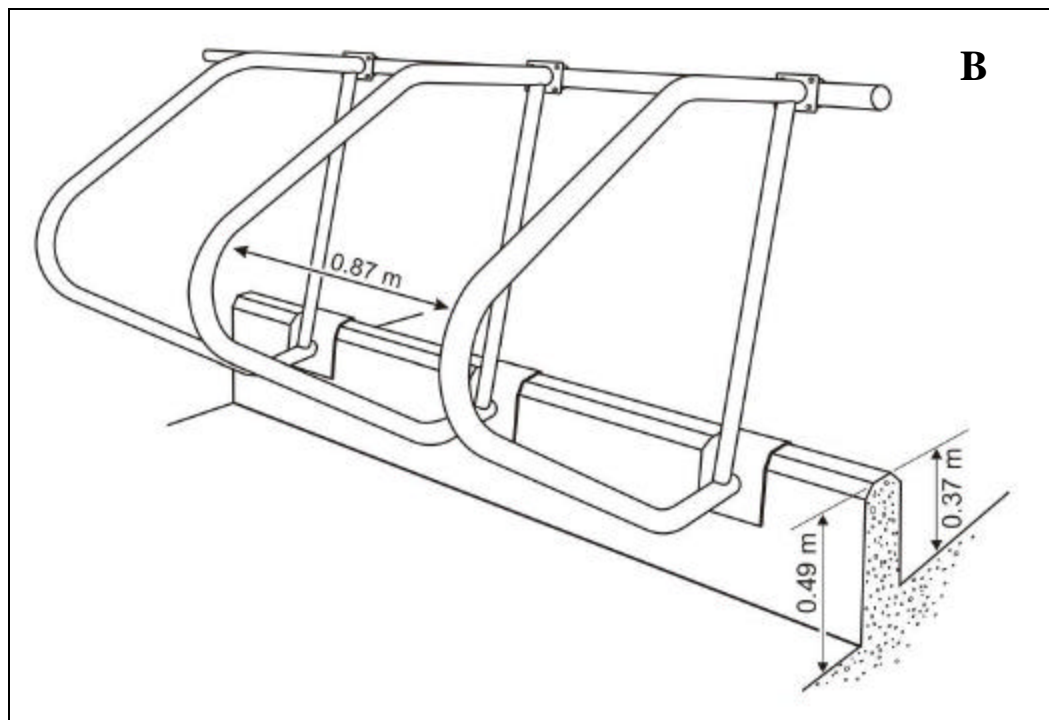
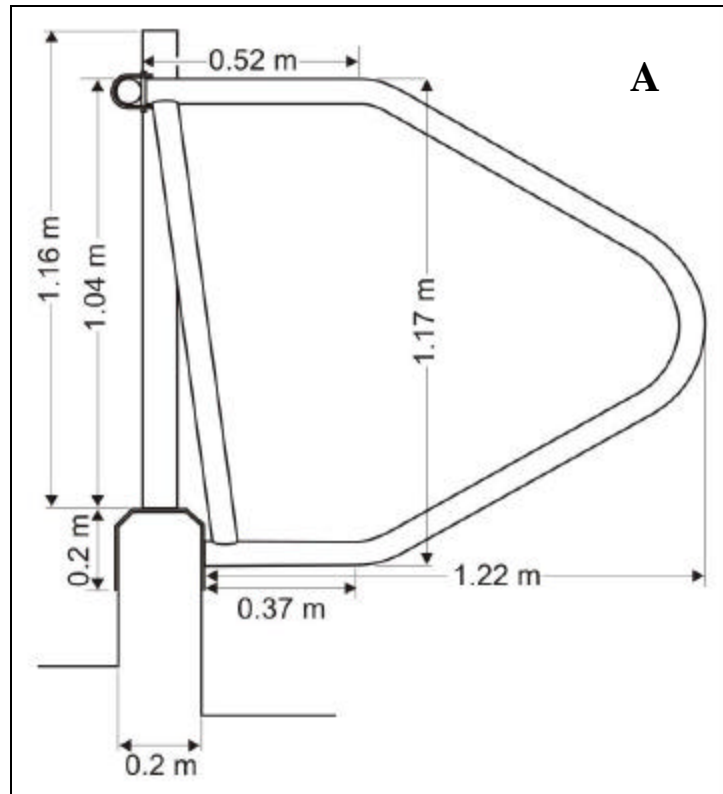

Figure 6.1. Diagrams of the (A) side and (B) rear-diagonal views of the feed stalls used in this study, showing the dimensions and placement of the feed stalls, respectively.

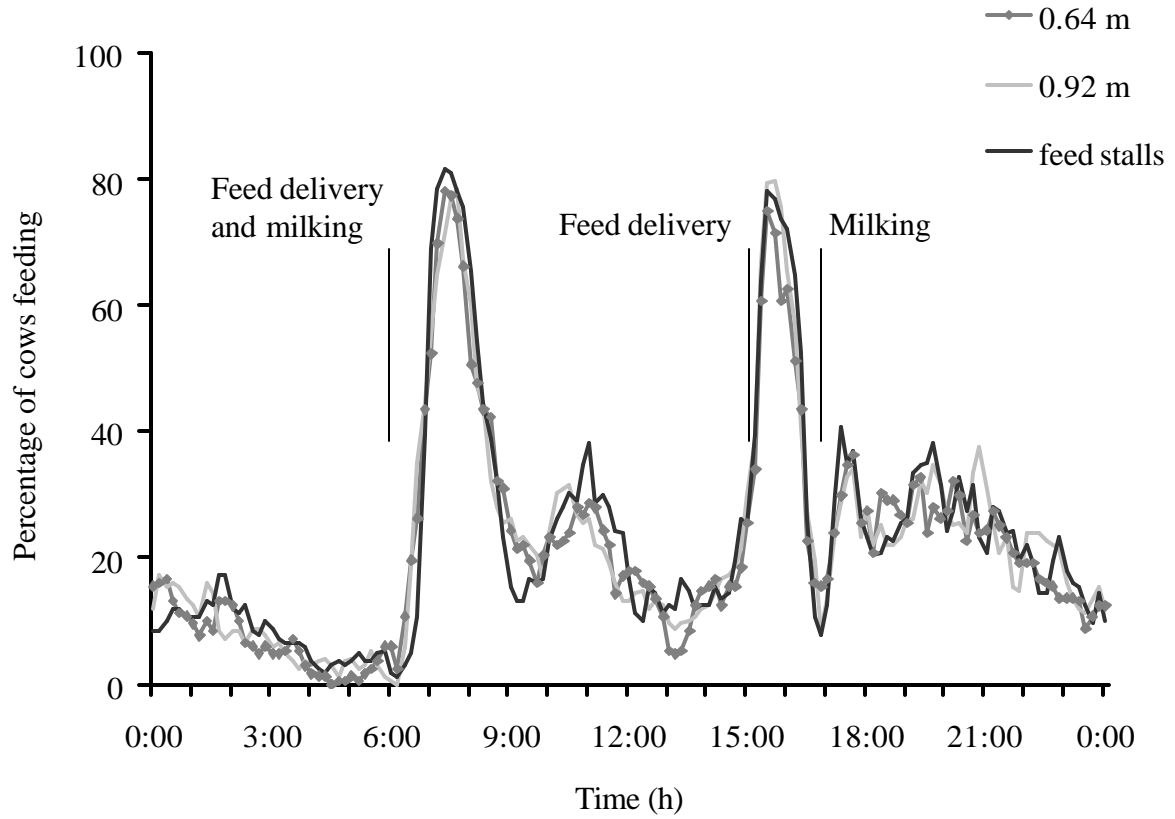

Figure 6.2. Percentage of cows per group present at the feed bunk over a 24-h period (percentage for each 60-s interval during the day) for 3 treatments: 1) 0.64 m of feed bunk space/cow, 2) 0.92 m of feed bunk space/cow, and 3) feed stalls (0.87 m of bunk space/cow with feed stall partitions). Data were averaged for 7 d per treatment for 3 groups, each containing 8 cows.

6.7 REFERENCES

- Anderson, I. L., K. E. Boe, and A. L. Kristiansen. 1999. The influence of different feeding arrangements and food type on competition at feeding in pregnant sows. *Appl. Anim. Beh. Sci.* 65:91-104.
- Barnett, J. L. 1997. Modifying the design of group pens with individual feeding places affects the welfare of pigs. Pages 613-618 in *Proceedings of the 5th International Livestock Environment Symposium*. R. W. Bottcher and S. J. Hoff, eds. American Society of Agricultural Engineers, Michigan, USA.
- Baxter, M. R. 1986. The design of the feeding environment for the pig. Ph.D. Diss., University of Aberdeen, UK.
- Bouissou, M.-F. 1970. Role du contact physique dans la manifestation des relations hierarchiques chez les bovines. Consequences pratiques. *Annales de Zootechnie*. 19:279-285.
- Canadian Council on Animal Care. 1993. Guide to the care and use of experimental animals. Vol. 1. E. D. Olfert, B. M. Cross, and A. A. McWilliam, ed. CCAC, Ottawa, Canada.
- DeVries, T. J. and M. A. G. von Keyserlingk. 2005. Time of fresh feed delivery affects the feeding and lying patterns of dairy cows. *J. Dairy Sci.* 88:625-631.
- DeVries, T. J., M. A. G. von Keyserlingk, and K. A. Beauchemin. 2003. Diurnal feeding pattern of lactating dairy cows. *J. Dairy Sci.* 86:4079-4082.
- DeVries, T. J., M. A. G. von Keyserlingk, and K. A. Beauchemin. 2005. Frequency of feed delivery affects the behavior of lactating dairy cows. *J. Dairy Sci.* 88:3553-3562.
- DeVries, T. J., M. A. G. von Keyserlingk, and D. M. Weary. 2004. Effect of feeding space on the inter-cow distance, aggression, and feeding behavior of free-stall housed lactating dairy cows. *J. Dairy Sci.* 87:1432-1438.
- Endres, M. I., T. J. DeVries, M. A. G. von Keyserlingk, and D. M. Weary. 2005. Effect of feed barrier design on the behavior of loose-housed lactating dairy cows. *J. Dairy Sci.* 88:2377-2380.
- Grant, R. J., and J. L. Albright. 2001. Effect of animal grouping on feeding behavior and intake of dairy cattle. *J. Dairy Sci.* 84 (E. Suppl.):E156-E163.
- Huzzey, J. M., T. J. DeVries, P. Valois, and M. A. G. von Keyserlingk. 2006. Stocking density and feed barrier design affect the feeding and social behavior of dairy cattle. *J. Dairy Sci.* 89:126-133.
- Konggaard, S. P. 1983. Feeding conditions in relation to welfare for dairy cows in loose-housing systems. Pages 272-280 in *Farm Animal Housing and Welfare*. S. H. Baxter, M. R. Baxter and J. A. D. MacCormack, eds. Martinus Nijhoff, Dordrecht, The Netherlands.

Mendl, M., A. J. Zanella, and D. M. Broom. 1992. Physiological and reproductive correlates of behavioural strategies in female domestic pigs. *Anim. Behav.* 44:1107-1121.

National Research Council. 2001. Nutrient requirements for dairy cattle. Natl. Acad. Sci. Washington, DC.

Olofsson, J. 1999. Competition for total mixed diets fed for ad libitum intake using one or four cows per feeding station. *J. Dairy Sci.* 82:69-79.

SAS Institute Inc. 1999. SAS Users Guide. SAS Institute Inc., Cary, NC.

CHAPTER 7: General discussion

The overall objective of my dissertation was to determine how feeding management and feed area design influence the behavior of group-housed lactating dairy cows. I addressed this objective in four steps: 1) defining feeding behavior measures and determining which of these measures are most repeatable and reliable for detecting treatment differences, 2) assessing the factors controlling feeding patterns, and 3) assessing the effects of feeding management and 4) feed area design on the behavior of group-housed lactating dairy cows. The general aim of my work was to provide scientifically based recommendations to producers concerning feed area design and management that ensure that all cows have reasonable access to feed with minimal displays of aggressive behavior.

7.1 MEASURING FEEDING BEHAVIOR

Researchers have suggested that the meal, rather than an individual feeding event, is the most biologically relevant unit for describing animal feeding behavior (Sibly et al., 1990; Tolkamp et al., 2000). This suggestion presents the challenge of objectively separating individual feeding events into meals. This objective separation has typically been accomplished with the use of a meal criterion, which distinguishes those intervals between feeding events that are between meals and from those that are within meals. Unfortunately, the literature has lacked a cohesive definition of a meal criterion (Grant and Albright, 1995). Methods proposed for calculating meal criteria have been criticized for being subjective or lacking biological meaning. Recently, Tolkamp and colleagues (Tolkamp et al., 1998; Tolkamp and Kyriazakis, 1999; Yeates et al., 2001) developed an objective method of establishing meal criteria that takes into account satiety. Although this work was the first to use this method for group-housed cows, these animals

were restricted to eating from feeding stations, which does not reflect common commercial practices. In Chapter 2 I was able to show that this method could also be applied to data obtained from group-housed animals fed at a feed bunk, a situation more reflective of commercial practice and one in which competitive interactions among cows are more common.

Since the work described in Chapter 2 was published, Huzzey et al. (2005) applied this method to calculate meal criteria for transition cows. These researchers noted a much larger range (5.3 to 105.2 min) in individual criteria compared to values reported previously. This difference may be attributed to a high degree of variation in feeding behavior in these cows, which may be the result of variable DMI and the major physiological changes occurring in these animals. Von Keyserlingk et al. (2004) also successfully used this method to determine the meal criterion for milk-fed calves. Feeding patterns of calves also follow the satiety concept and, thus, lend themselves to this type of calculation. Since the satiety concept applies to all animals, it is recommended this objective method of criteria calculation be preferred and be applied to other species of animals in future research.

Chapter 2 also describes how meal measures can best be applied to feeding behavior in dairy cows. Even though individual cows differed to some degree in their meal criteria, there was no difference between those feeding behavior measures calculated using a pooled (from all animals) criterion (27.7 min) and those calculated with the individual criteria, leading me to conclude that for some studies (i.e. where cows are at the same stage of lactation, at similar body condition, and fed the same diet) a pooled estimate is adequate. I also noted that in some cases where there is considerable variation in criteria (e.g. between cows or time periods) it would be recommended to use individual criteria. This statement was confirmed by Huzzey et al. (2005), who also calculated individual and pooled meal criteria. Even though the pooled criterion (26.4

min) in that study was similar to that reported in Chapter 2, these researchers found that the pooled criterion underestimated meal frequency. Therefore, I recommend that researchers exercise caution when using a pooled meal criterion.

The main application of the meal criterion calculated in Chapter 2 was to calculate meal-based measures of feeding behavior, including meal frequency, duration, and total daily meal time. I then set out to determine which measures of feeding behavior are most repeatable and, thus, reliable for detecting treatment differences. Even though several researchers (e.g. Vasilatos and Wangness, 1980; Dado and Allen, 1994; Nielsen, 1999) have examined the relationships between various measures of feeding behavior, my work is the first to quantify the repeatability of these measures in dairy cattle. All of the measures of feeding behavior used in Chapter 2 were related between different stages of lactation. Further, the non-derived measures (e.g. time spent feeding) showed far superior repeatability than the criterion derived measures (e.g. meal frequency). I, therefore, recommend that researchers, as I did in my subsequent work, use these measures in assessing treatment effects on feeding behavior in future studies.

I must mention, however, that in contrast to my findings, Huzzey et al. (2005) argued that for transition cows meal frequency was a more consistent measure of feeding behavior than feeding time across the pre- and post-calving periods. Again, the discrepancy between this result and that found in Chapter 2 is most likely due to the physiological stage of the cows used by Huzzey et al. (2005), which may have caused the high variability in daily time spent feeding and resultant inconsistency between pre- and post-calving periods. Despite this recent finding, I am confident that the use of time spent feeding in this dissertation is justified because the animals I used were all in the same stable stage of lactation (i.e. between peak and mid-lactation). Further,

in all the studies described in my dissertation the treatment periods were relatively short; therefore, I did not expect nor did I see any time-related changes in feeding behavior.

7.2 FEEDING PATTERNS

The second approach in meeting my overall objective was to assess the factors controlling the feeding patterns of group-housed lactating dairy cows. The results of Chapter 3 clearly indicate that the delivery of feed has the greatest effect in terms of stimulating feeding activity in group-housed dairy cattle and is the primary influence in determining their daily feeding patterns. This finding contradicts the idea that the diurnal feeding patterns of dairy cattle are primarily influenced by the time of day. It has long been accepted that dairy cattle exhibit a diurnal feeding pattern where the majority of feeding activity occurs during the daylight hours, particularly around sunrise and sunset (Albright, 1993). However, this observation is almost exclusively based on the feeding patterns exhibited by grazing cattle. Although some researchers have shown that this pattern of feeding activity also occurs in both tie-stall housed dairy cattle (Vasilatos and Wangsness, 1980) and free-stall housed dairy cattle (DeVries et al., 2003), it must be noted that in these studies the management practices of milking and feeding occur in the early morning and late afternoon, which are the times when dairy cattle are traditionally believed to engage in most of their feeding activity. Further, in several other studies using dairy cattle, the times of peak feeding activity have often been associated with the time of feed delivery and milking, regardless of the time of day at which they occurred (Suzuki and Hidari, 1973; Tanida et al., 1984; Haley et al., 2000; Wagner-Storch and Palmer, 2003). Therefore, these studies support the finding in Chapter 3 that it is the management practice of feed delivery that acts as

the primary influence on the daily feeding pattern of lactating dairy cows and not, as previously thought, the time of day.

Since my work on this area was published, Shabi et al. (2005) published a study where they investigated the within-day feeding behavior of lactating dairy cows. These authors modeled the feeding rate of the cows over the course of the day and reported two peaks in feeding rate, which were normally distributed. They went on to conclude that cows exhibit a crepuscular eating pattern, being most active at sunrise and sunset. Although this conclusion contradicts that reported in Chapter 3, on closer inspection of their data it is apparent that they may have misinterpreted their findings. Although the rate of intake appears to be greatest at sunrise and sunset, the authors failed to consider the time of day when DMI was greatest. The cumulative consumption data in Shabi et al. (2005) indicates that the actual amount of feed intake peaked after the time of feed delivery (1100 h), and persisted for a few hours. This clearly shows that the feeding pattern of the cows peaked during this period, and not at sunrise (0508 h) and sunset (1818 h) as indicated by the authors. These data thus provide further evidence that the feeding patterns of grouped indoor-housed cattle are primarily influenced by feed delivery and not by an innate rhythm as previously thought.

7.3 FEEDING MANAGEMENT

The experiment described in Chapter 3 clearly demonstrated that the act of fresh feed delivery provides the greatest motivator for cows to feed. However, in this work I also reported a notable response in feeding behavior during the period immediately after milking. The separation of feed delivery from the time of milking resulted in four peaks in feeding behavior throughout the day, likely contributing to the increase in daily feeding time by the cows. These

results indicate that when the time of feed delivery is moved away from milking time, there are increased opportunities to access feed.

The fact that cows are highly motivated to access the feed bunk upon the delivery of feed provided evidence that increasing the frequency of feed delivery should improve the ability of cows to access freshly delivered feed. For that reason, in Chapter 4, I tested the effects of frequency of feed delivery (once, twice, and four times per day) on the feeding behavior of lactating dairy cows. The results clearly indicated that increasing the frequency of feed delivery allowed for more equal access (among cows) to freshly delivered feed and also resulted in a more even distribution of feeding time over the course of the day. It has been suggested that feed access may be more important than the actual amount of nutrients provided (Albright, 1993). Allowing all cows access to feed at times when they show the greatest motivation to feed should allow them to meet their nutritional requirements in a manner which minimizes any feeding behavior patterns that may result in negative health and production effects. An example of one such negative pattern would be cows consuming their feed in a few large meals (i.e. slug feeding), which increases their risk of such diseases as sub-acute ruminal acidosis (Shaver, 2002). The work described in Chapter 4 shows that given the opportunity, cows will distribute their feeding time more evenly over the day. This more even distribution will in turn result in a steady input of nutrients into the rumen over the course of the day, potentially decreasing the diurnal variation in ruminal pH and risk of sub-acute ruminal acidosis.

In both Chapters 3 and 4 I also looked at the effects that feed delivery has on lying behavior in dairy cows. Although time spent feeding increased when delivery of fresh feed was shifted by 6 h and when the frequency of feed delivery was increased, I did not find any change in total daily lying time. These results indicate that the increase in time spent feeding noted in

these experiments most likely came out of the time cows otherwise spent idle waiting for feed or for access to the feeding area. Cows did however change their pattern of lying behavior in both Chapters 3 and 4 when the management of feed delivery was altered, with notable differences in lying behavior patterns occurring in the period after cows returned from milking. Cows lay down sooner after milking in those cases when no fresh feed was delivered at the time of milking and when the daily frequency of feed delivery was high. The practical significance of these findings is not fully understood. The common assumption is that the longer the animal stands after milking the more the teat becomes constricted, and thus, the risk for bacterial penetration of the teats when the cow eventually lies down is reduced. There is no clear evidence in the literature when after milking the teat is most constricted and the risk of penetrability by bacteria is lowest. Also, in the studies presented in Chapters 3 and 4, the restricted length of the treatment periods and the total number of animals made it impossible to test for any treatment effect on the incidence of mastitis. Whether decreased latency to lie following milking should be considered as a risk factor is not clear and I recommend more work investigating the relationships between standing time after milking, teat constriction and risk of mastitis.

Since changes in feed intake must be mediated by changes in feeding behavior, I examined how feeding management influences the DMI of the cows. In both Chapter 3 and 4, there were no effects of treatment on DMI. Further, in Chapter 3 I tested the effect of treatment on milk yield, and also found no effect. Despite these lack of differences, I caution that these experiments were designed to test predictions concerning feeding behavior, and do not provide a strong test of differences in intake. Since the cows were fed as a group in each study, I was only able to obtain group DMI. Such a measurement is very rudimentary and imprecise due to both the feed delivery and ort collection procedure using a large, feed-mixing wagon. Also, although

the short treatment periods were sufficient for detecting feeding behavior differences, the treatment periods were too short to note any difference in milk production. Therefore, I recommend that the effect of feeding management on DMI and milk yield be assessed in future studies using equipment that accurately measures individual DMI and longer treatment periods be implemented to assess the effect of these treatments on milk yield.

In addition to feed intake and milk production, feed sorting is a practical concern for dairy producers. Cows have been shown to preferentially sort for the grain component of a TMR, leaving the longer forage components. This behavior results in an increase in the fiber content of the remaining feed (Leonardi and Armentano, 2003). It is commonly believed that the greatest amount of feed sorting occurs when the frequency of feed delivery is low (e.g. Shaver, 2002), but there is little scientific evidence supporting this claim. The results of Chapter 4 are the first to show that the amount of sorting is influenced by the frequency of feed delivery. Although sorting occurred at all frequencies of feed delivery, the greatest amount occurred when cows were delivered feed once per day. High amounts of sorting can result in cows consuming a ration that is not balanced to meet their nutritional requirements. Those cows accessing the feed bunk at the time of feed delivery may end up consuming a ration that is too high in energy and those cows that do not have access to feed at this time may end up consuming a ration that is not balanced to meet their nutritional requirements. Cook et al. (2004) suggested that consumption patterns rather than total feed intake appear to be important in the development of sub-acute ruminal acidosis. Therefore, with less sorting, more equal access to freshly delivered feed and a more even distribution of feeding time over the course of the day, increasing the frequency of feed delivery has the potential to reduce the variation in diet quality consumed by the cows and reduce the risk of sub-acute ruminal acidosis. This needs to be substantiated in a future study in

which the researchers accurately measure both individual feed intake and rumen parameters (i.e. diurnal fluctuations in ruminal pH).

Cook et al. (2004) also suggested the need to consider the effect of reduced feed access on subordinate cows. Subordinates may be forced to alter daily activity patterns and feed at the bunk only after dominant cows have sorted the fresh feed. For this reason, I also considered in Chapters 4 the effects of frequency of feed delivery on those cows that were displaced most often from the feed bunk, and thus were prevented from accessing feed when they wanted to. The results indicated that the frequency of displacements involving subordinate cows was reduced when the group was fed more often, indicating that providing feed more frequently may improve access to feed for all cows, especially during periods when fresh feed is available, and reduce the variation in diet consumed by these cows. The results of Chapter 4 also indicated that those cows that were displaced least often from the feed bunk during the low frequency of feed delivery treatment were displaced at a slightly higher frequency when exposed to the higher frequency of feed delivery treatments. Therefore, at higher frequencies of feed delivery, these cows may not be able to have large extended meals during which they may be preferentially sorting for the grain component of the diet, possibly reducing the risk of sub-acute ruminal acidosis in these animals. Again, this was not within the scope of my dissertation research and I recommend further work be undertaken in this area.

Despite changes in the frequency of displacements for both subordinate and dominant cows, I found no effect of the frequency of feed delivery on the daily incidence of displacements. I noted the same finding in Chapter 3, where the timing of feed delivery also had no effect on the total incidence of displacements at the feed bunk. Regardless of these findings, high levels of aggression at the feed bunk were noted in both experiments. This suggests that other factors must

influence the level of competition at the feed bunk and the ability of cows to access feed when they want to.

7.4 FEED AREA DESIGN

It has been suggested that well designed systems allow for normal feeding behavior, which, in turn, allow for improved cow comfort and well-being (Grant and Albright, 2000). For this reason, the final two studies (Chapters 5 and 6) described in this dissertation assessed the effects of feed area design on the behavior of group-housed lactating dairy cows. There are several components of the feeding area that have the potential to influence ability of cows to access feed, including the amount of available feed bunk space and the physical design of the feeding area.

The first factor that I investigated in my quest to improve access to feed and reduce competition at the feed bunk was the amount of available feed bunk space. Since researchers have shown that the present industry recommendation of 0.6 m of feed bunk space fails to allow all animals access to feed at a given time (Friend and Polan, 1974; DeVries et al., 2003), I set out to determine if providing a greater amount of feed bunk space could increase the ability of cows to access feed. In Chapter 5, I was able to show that increasing the amount of feed bunk space from 0.5 m to 1.0 m per cow resulted in animals spacing themselves further apart while feeding, regardless of the number of cows present at the feed bunk. This result is similar to the finding of Kondo et al. (1989) that cows tend to increase their inter-individual distances as floor space allowance was increased. These results seem to indicate that at low levels of space allowance, whether it is feed bunk space or floor space, cows are forced to stand closer to each other than what they normally would.

Given that cows elect to stand further apart when provided more linear bunk space per animal, I was not surprised to also find reduced aggressive behavior in this condition. In Chapter 6, I replicated these results finding a large reduction in displacements from the feed bunk when bunk space was increased from 0.64 m to 0.92 m per cow. These results have also been replicated in a dose-response study by Huzzey et al. (2006). Interestingly, in that study, these researchers also found that the number of times cows were displaced from the feeding area increased in an accelerated fashion as stocking density increased (i.e. with less available feed bunk space/cow).

In Chapter 5, the changes in spacing and aggressive behavior in turn allowed the cows to increase their daily feeding time by 14%. Similarly, in Chapter 6, when feed bunk space was increased from 0.64 to 0.92 m/cow, daily feeding time increased by 4.6%. Further, in the study by Huzzey et al. (2006), a moderate increase in feed bunk space (from 0.61 to 0.81 m/cow) resulted in a 1.2% increase in daily feeding time. These results provide evidence that lactating dairy cattle appear to realize greater benefits in terms of increased time spent feeding, and therefore greater access to feed, when provided with increasing amounts of available feed bunk space. This thought is reflected in the study by Huzzey et al. (2006), where feeding time was found to decrease in an accelerating fashion with increased density at the feed bunk, indicating that incremental increases in stocking density resulted in larger decreases in feeding time.

A large part of the increase in daily feeding time in Chapter 5 was seen in the time after feed delivery. As shown in Figure 5.1, a larger proportion of the cows were at the feed bunk during this period when cows had 1.0 m of feed bunk space/cow. In Chapter 6, the effect of feed bunk space on the proportion of cows at the feed bunk was less noticeable. As seen in Figure 6.2, treatment differences were limited to the period after the afternoon delivery of feed. This

discrepancy between results in Chapters 5 and 6 may be due to the more moderate difference in feed bunk space tested in Chapter 6. Despite this, I hesitate to conclude that the more moderate increase in bunk space tested in Chapter 6 was not effective in increasing access to fresh feed. Chapter 6 clearly showed that there were fewer cows inactively standing in the feeding area when they had 0.92 m of bunk space compared to when they had 0.64 m. This is similar to the finding by Huzzey et al. (2006), who also reported that inactive standing was lower during periods of peak feeding activity when stocking density at the feed bunk was decreased. When bunk space is limited, some cows may be forced to stand and wait for an available feeding spot. This would translate into high inactive standing times. Therefore, the lower percentage of cows standing inactively in Chapter 6 with 0.92 m of bunk space/cow indicates that at this increased level of bunk space there are fewer cows waiting for feeding spots, and presumably, increased access to fresh feed.

Even though the additional feed bunk space in both Chapters 5 and 6 reduced competition at the feed bunk and increased feed access, displacements from the feed bunk were not eliminated, suggesting that there are additional factors contributing to aggressive behavior. Because research undertaken with other domesticated species has indicated that the configuration of feeding spaces can have profound effects on feeding competition, I predicted that the physical design of the feeding area must play an important role in reducing competition at the feed bunk.

Until recently, there has been limited data on the effect of feed area design on dairy cattle behavior. In two recent studies (Endres et al., 2005; Huzzey et al., 2006), two types of feed line barriers were compared: the post-and-rail barrier and the headlock barrier (see Figure 1.3). In both studies, the use of the headlock barrier reduced the incidence of displacements at the feed bunk. However, they did not completely eliminate aggressive behavior at the feed bunk,

indicating that the neck division does not provide full protection. Researchers have demonstrated in pigs (Baxter, 1986; Barnett, 1997; Andersen et al., 1999) and cattle (Bouissou, 1970) that providing partitions that separate the bodies of adjacent animals can have profound effects on reducing competition and allowing animals to feed for longer periods. Therefore, I was interested in determining if the addition of partitions (feed stalls – see Figure 6.1) between adjacent cows provides additional protection while feeding and allows for improved access to feed.

The design of the feed stalls changed the displacement strategy of the cows. The presence of the vertical bar at the front of the partition likely accounted for the 69% decrease in the number of displacements that stemmed from contact initiated at the front of the displaced cow. The vertical bar likely minimized any attempts by the cows to swing their head from side to side in an attempt to displace another cow. However, as shown by Endres et al. (2005) and Huzzey et al. (2006), this may not be enough, hence the need for the body partitions. The presence of the body partitions located between adjacent cows likely contributed to large reductions in the number of displacements instigated at the side of the displaced cow. With reduced ability to initiate contact on the front and side of the body of another cow with the feed stalls, the cows were forced to increase the number of displacements which they instigated by contact on the rear of another cow. In spite of this, overall the feed stalls decreased the number of aggressive interactions at the feed bunk.

Despite the change in displacement strategy and overall reduction in the number of displacements, the majority of the displacements were initiated from the front and from the side of the animal being displaced. This indicates that the design of the feed stalls in Chapter 6 could be improved to further reduce aggressive behavior at the feed bunk. It is possible that displacements from the side could be completely eliminated by closing in the feed stalls (i.e.

possibly with some diagonally placed bars). Further, displacements from the front could be reduced by including a partition on the feed side of the bunk, as suggested by the study by Bouissou (1970). I encourage future work to assess these alternative feed stalls designs.

The design of the feed stalls used in Chapter 6 created a defined feeding position for each cow and, as noted above, dramatically reduced the frequency of competitive behavior at the feed bunk. The stalls also allowed cows to feed for longer periods of time and spend less time inactively standing in the feeding area. This decrease in inactive standing was particularly noticeable during the peak-feeding period following the afternoon delivery of feed, when there was also an increase in the percentage of cows feeding when they had the feed stalls. These results provide further evidence that the provision of the feed stalls allows for better access to fresh feed.

Another potential benefit of a decrease in inactive standing time when using the feed stalls may be improved hoof health. It has been suggested that cows exhibiting longer standing times, especially on hard surfaces, are at a higher risk of developing hoof and leg injuries (Greenough and Vermunt, 1991). Unfortunately, in Chapter 6, the reduction in inactive standing time was less than the increase in feeding time, meaning that the cows were actually spending more time standing on the hard concrete floor of the feed alley. This difference would possibly not be a problem if the cows were provided with an elevated, softer flooring surface to stand on at the feed bunk. When using the feed stalls, one could create an elevated standing surface, just long enough for the cows to stand on, such that all defecations and urination would occur in the alley. This would ensure that the hooves of the cows would stay out of the manure, which has been reported to be risk factor for hoof injuries. Borderas et al. (2004) reported that cows standing in high moisture environments, such as those often seen in free-stall environments that

contain excessive amounts of manure, have softer claws and are at a higher risk for lameness. Providing a softer flooring surface on such a platform may reduce the risk of hoof and leg injuries, as suggested by Greenough and Vermunt (1991). Further, such a surface may also encourage longer feeding times, as researchers have shown that cows prefer to stand on softer flooring surfaces than concrete (Tucker et al., 2003; Fregonesi et al., 2004). I must note that these combined effects of feed stalls and an elevated soft standing surface on hoof health are quite speculative and, therefore, I encourage future research to assess these properly.

Dairy cattle are known to synchronize their behavior (Miller and Wood-Gush, 1991; Rook and Huckle, 1995), however researchers have shown that synchronization is reduced when cattle are housed intensively indoors (O'Connell et al. 1989; Miller and Wood-Gush, 1991). The results of Chapters 5 and 6 indicate that the provision of more defined feeding positions, through increased bunk space and feed stalls, will allow cows' better access to feed and thus increase the synchronization of their feeding behavior. These results also suggest that the reduction in feeding synchrony noted by previous researchers may be due to competition for available feeding positions at the feed bunk. Therefore, in situations where feeding spots are limited, increased competition among cows at the feed bunk may lead to some cows modifying their feeding times to avoid aggressive interactions (Miller and Wood-Gush, 1991). This may not only be frustrating for the cows, since it will prevent them from performing their innate synchronization behavior (Friend, 1991), but it will also have unintended nutritional consequences for those cows that do not have access to feed at the time of delivery. It has been suggested that feeding a complete ration (such as a TMR) is important when feeding space is limited so that all cows will consume the same quality feed, regardless of when they access the feed bunk (Friend and Polan, 1974). Unfortunately, as shown in Chapter 4, the sorting of a TMR can reduce the quality of the feed,

particularly in the later hours after feed delivery. Therefore, in situations where there are limited positions for feeding at the feed bunk, some cows may be forced to wait for access while others occupy the feed bunk, resulting in large between-cow variation in the composition of ration consumed.

I was also able to demonstrate which animals would have limited access to fresh feed at the feed bunk when feed bunk space was limiting. In Chapter 5, the analyses of feeding behavior during peak periods of feeding activity (i.e. such as after the delivery of feed) indicated that subordinate cows were most limited in terms of access to the feed bunk at low levels of bunk space. This finding is supported by the results of Huzzey et al. (2006), who demonstrated that at high stocking densities at the feed bunk, subordinate cows were displaced more often than their dominate counterparts compared to when more bunk space was available. These results also confirm the assumption by Friend and Polan (1974) that in situations where there is competition at the feed bunk, subordinate cows would likely be most limited in their access to the feed during times of peak feeding activity.

There are, however, ways that these negative effects on subordinate cows can be mitigated. In Chapters 5, I showed that increasing the available bunk space caused the subordinate cows to have the greatest increase in feeding time during the periods of peak activity. Further, in Chapter 6, the addition of the feed stalls provided the greatest benefits in terms of reducing the number of times the subordinate cows were displaced per day. Thus, it appears that increasing amounts of feed bunk space, particularly when combined with feed stalls, improves the feeding conditions for subordinate animals that typically have difficulty accessing feed at times when they have the greatest desire to feed. In a recent review, Cook et al. (2004) argued that the majority of researchers who have studied stocking density at the feed bunk have

failed to consider how increased competition at the feed bunk affects individual cows. These researchers further suggest that we need to consider the effects of reduced feed access on subordinate cows. They speculate that these cows may be forced to alter daily activity patterns and feed at the bunk only after dominant cows have sorted the fresh feed. My dissertation research has addressed this gap in the literature, and, as Cook et al. (2004) suggest, allows me to recommend the use of improved feed area designs (i.e. increased feed bunk space, use of feed stalls) over those commonly seen in modern barns.

Feed area designs that improve bunk access may be particularly important for early lactation cows. Immediately after calving, cows are typically introduced into a new group of unfamiliar lactating cows. It has been suggested that these cows often face increased competition within their new group (Grant and Albright, 1995), which may in turn limit their access to feed. Further, it is known that these cows often fail to meet their nutritional requirements during this time period and succumb to disease (Drackley, 1999) Therefore, it seems likely that increasing feed bunk space, particularly with the addition of feed stalls, will act to improve the nutritional status of these cows. New research is now required to directly test whether reduced competition at the feed bunk and improved feed access decreases susceptibility to those diseases common around calving and improves production in early lactation cows.

It is also possible that reducing competition may have long term effects on dairy cows. In a stocking density experiment by Leonard et al. (1998), it was found that cows that were engaged in a high number of aggressive interactions at the feed bunk during the experiment had more severe claw-horn lesions 3 mo after the experiment compared to those animals that did not engage in such interactions. To my knowledge, this is the only research to date which has shown a link between hoof health and the effects of feed area design. It is not known whether these

results are repeatable, and the mechanisms underlying this finding are not clear, so more work is clearly required in this area.

7.5 CONCLUDING REMARKS

The overall objective of this dissertation was to determine how feeding management and feed area design influence the behavior of group-housed lactating dairy cows; an objective that I believe was largely achieved. My work has provided a greater understanding of feeding behavior in group-housed cows. For example, I clearly showed how the timing of feed delivery influences feeding behavior patterns of group-housed lactating dairy cattle. Further, using this knowledge, I was able to demonstrate that frequent delivery of feed improves access to feed for all cows, particularly during peak feeding periods when fresh feed is provided, and reduces the degree of feed sorting. In addition, my work has furthered our understanding of how feed area design affects dairy cattle behavior. This research clearly demonstrated that the provision of increased feed bunk space above that typically provided, particularly when combined with feed stalls, will improve access to feed and reduce competition at the feed bunk, particularly for subordinate cows. These findings all provide insight into how one can manage and design the feeding area to increase access to feed, reduce competition at the feed bunk, and reduce the between-cow variation in the composition of feed consumed. Future work is now required to fully understand the long-term implications of feeding management and feeder design on the DMI, milk production, hoof health, and disease incidence of lactating cows at the various stages of their lactation cycle.

7.5 REFERENCES

- Albright, J. L. 1993. Feeding behavior in dairy cattle. *J. Dairy Sci.* 76:485-498.
- Anderson, I. L., K. E. Boe, and A. L. Kristiansen. 1999. The influence of different feeding arrangements and food type on competition at feeding in pregnant sows. *Appl. Anim. Beh. Sci.* 65:91-104.
- Barnett, J. L. 1997. Modifying the design of group pens with individual feeding places affects the welfare of pigs. Pages 613-618 in Proceedings of the 5th International Livestock Environment Symposium. R. W. Bottcher and S. J. Hoff, eds. American Society of Agricultural Engineers, Michigan, USA.
- Baxter, M. R. 1986. The design of the feeding environment for the pig. Ph.D. Diss., University of Aberdeen, UK.
- Bouissou, M.-F. 1970. Role du contact physique dans la manifestation des relations hiérarchiques chez les bovines. Consequences pratiques. *Annales de Zootechnie.* 19:279-285.
- Borderas, T. F., Pawluczuk, B., de Passillé, A. M., and Rushen, J. 2004. Claw hardness of dairy cows: relationship to water content and claw lesions. *J. Dairy Sci.* 87: 2085-2093.
- Cook, N. B., K. V. Nordlund, and G. R. Oetzel. 2004. Environmental influences on claw horn lesions associated with laminitis and subacute ruminal acidosis in dairy cows. *J. Dairy Sci.* 87: E36-46E.
- Dado, R. G., and M. S. Allen. 1994. Variation in and relationships among feeding, chewing, and drinking variables for lactating dairy cows. *J. Dairy Sci.* 77:132-144.
- Dado, R. G., and M. S. Allen. 1995. Intake limitations, feeding behavior, and rumen function of cows challenged with rumen fill from dietary fiber or inert bulk. *J. Dairy Sci.* 78:118-133.
- DeVries, T. J., M. A. G. von Keyserlingk, and K. A. Beauchemin. 2003. Diurnal feeding pattern of lactating dairy cows. *J. Dairy Sci.* 86:4079-4082.
- Drackley, J. K. 1999. Biology of dairy cows during the transition period: The final frontier? *J. Dairy Sci.* 82:2259-2273.
- Endres, M. I., T. J. DeVries, M. A. G. von Keyserlingk, and D. M. Weary. 2005. Effect of feed barrier design on the behavior of loose-housed lactating dairy cows. *J. Dairy Sci.* 88:2377-2380.
- Fregonesi, J.A., C.B. Tucker, D.M. Weary, F.C. Flower, and T. Vittie. 2004. Effect of rubber flooring in front of the feed bunk on the behavior of dairy cattle. *J. Dairy Sci.* 87:1203-1207.
- Friend, T. H. 1991. Behavioral aspects of stress. *J. Dairy Sci.* 74:292-303.

- Friend, T. H., and C. E. Polan. 1974. Social rank, feeding behavior, and free stall utilization by dairy cattle. *J. Dairy Sci.* 57:1214-1220.
- Grant, R. J., and J. L. Albright. 1995. Feeding behavior and management factors during the transition period in dairy cattle. *J. Anim. Sci.* 73:2791-2803.
- Grant, R. J., and J. L. Albright. 2000. Feeding Behaviour. Pages 365-382 in *Farm Animal Metabolism and Nutrition*. J. P. F. D'Mello, ed. CABI Publishing, Wallingford, Oxon, UK.
- Greenough, P. R., and J. J. Vermunt. 1991. Evaluation of subclinical laminitis in a dairy herd and observations on associated nutritional and management factors. *Vet. Rec.* 128:11-17.
- Haley, D. B., J. Rushen, and A. M. de Passille. 2000. Behavioural indicators of cow comfort: activity and resting behaviour of dairy cows in two types of housing. *Can. J. Anim. Sci.* 80:257-263.
- Huzzey, J.M., M.A.G. von Keyserlingk and D.M. Weary. 2005. Changes in feeding, drinking, and standing behavior of dairy cows during the transition period. *J. Dairy Sci.* 88:2454-2461.
- Huzzey, J. M., T. J. DeVries, P. Valois, and M. A. G. von Keyserlingk. 2006. Stocking density and feed barrier design affect the feeding and social behavior of dairy cattle. *J. Dairy Sci.* 89:126-133.
- Kondo, S., J. Sekine, M. Okubo, and Y. Asahida. 1989. The effect of group size and space allowance on the agonistic spacing behaviour of cattle. *Appl. Anim. Behav. Sci.* 24:127-135.
- Leonard, F. C., I. Stienezen, and K. J. O'Farrell. 1998. Overcrowding at the feeding area and effects on behavior and claw health in Friesian heifers. Pages 40-41 in *Proc. 10th Int. Symp. Lameness in Ruminants*, Lucerne, Switzerland.
- Leonardi, C., and L. E. Armentano. 2003. Effect of quantity, quality, and length of alfalfa hay on selective consumption by dairy cows. *J. Dairy Sci.* 86:557-564.
- Miller, K., and D. G. M. Wood-Gush. 1991. Some effects of housing on the social behaviour of dairy cows. *Anim. Prod.* 53:271-278.
- Nielsen, B. L. 1999. On the interpretation of feeding behaviour measures and the use of feeding rate as an indicator of social restraint. *Appl. Anim. Behav. Sci.* 63:79-91.
- O'Connell, J., P. S. Giller, and W. Meaney. 1989. A comparison of dairy cattle behavioural patterns at pasture and during confinement. *Irish J. Agr. Res.* 28:65-72.
- Rook, A. J., and C. A. Huckle. 1995. Synchronization of ingestive behaviour by grazing dairy cows. *Anim. Sci.* 60:25-30.

- Shabi, Z., M. R. Murphy, and U. Moallem. 2005. Within-day feeding behavior of lactating dairy cows measured using a real-time control system. *J. Dairy Sci.* 88:1848-1854.
- Shaver, R. D. 2002. Rumen acidosis in dairy cattle: Bunk management considerations. *Advances in Dairy Technology.* 14:241-249. University of Alberta, Edmonton, Alberta, Canada.
- Sibly, R. M., H. M. R Nott, and D. J. Fletcher. 1990. Splitting behaviour into bouts. *Anim. Behav.* 39:63-69.
- Suzuki, S., and H. Hidari. 1973. Effects of the time feed given on the diurnal feeding pattern of dairy cows. *Jap. J. of Zootech. Sci.* 44:216-221.
- Tanida, H., L. V. Swanson, and W. D. Hohenboken. 1984. Effect of artificial photoperiod on eating behavior and other behavioral observations of dairy cows. *J. Dairy Sci.* 67:585-591.
- Tolkamp, B. J., and I. Kyriazakis. 1999. To split behaviour into bouts, log-transform the intervals. *Anim. Behav.* 57:807-817.
- Tolkamp, B. J., D. J. Allcroft, E. J. Austin, B. L. Nielsen, and I. Kyriazakis. 1998. Satiety splits feeding behaviour into bouts. *J. Theor. Biol.* 194:235-250.
- Tolkamp, B. J., D. P. N. Schweitzer, and I. Kyriazakis. 2000. The biologically relevant unit for the analysis of short-term feeding behavior of dairy cows. *J. Dairy Sci.* 83:2057-2068.
- Tucker, C. B., Weary, D. M., and Fraser, D. 2003. Effects of three types of free-stall surfaces on preferences and stall usage by dairy cows. *J. Dairy Sci.* 86: 521-529.
- Vasilatos, R., and P. J. Wangsness. 1980. Feeding behavior of lactating dairy cows as measured by time-lapse photography. *J. Dairy Sci.* 63:412-416.
- von Keyserlingk, M. A. G., L. Brusius and D. M. Weary. 2004. Competition for teats and feeding behavior of group-housed calves. *J. Dairy Sci.* 87:4190-4194.
- Wagner-Storch, A. M., and R. W. Palmer. 2003. Feeding behavior, milking behavior, and milk yields of cows milked in a parlor versus an automatic milking system. *J. Dairy. Sci.* 86:1494-1502.
- Yeates, M. P., B. J. Tolkamp, D. J. Allcroft, and I. Kyriazakis. 2001. The use of mixed distribution models to determine bout criteria for analysis of animal behaviour. *J. Theor. Biol.* 213:413-425.

APPENDIX 1: Validation of a system for monitoring feeding behavior of dairy cows^{6?}

The time spent eating, and the pattern of meals, can obviously have important effects on total daily intake of dairy cattle (Grant and Albright, 2000). For that reason, a great deal of recent research in dairy nutrition and management has focused not only on changes in intake, but also on changes in feeding behavior. Over the past few decades, management of North American dairy farms has moved from tie-stall systems to loose-housing systems such as free stalls. This move to loose housing has made the collection of feeding behavior data more difficult. Traditionally, feeding behavior of loose-housed cows was monitored through direct human observation, but this method is labor intensive, making observations on multiple animals and days difficult. The use of time-lapse video recordings (Friend et al., 1977; Vasilatos and Wangsness, 1980) increases the ability to monitor many animals for multiple days; however, transcription of these videos is also labor intensive.

With the introduction of various individual intake monitoring systems, researchers (e.g. Tolkamp et al., 2000) have collected continuous feeding behavior data for loose-housed cows. However, cows using these systems are required to access feed via an electronic gate, potentially changing feeding behavior compared to that in commercial loose-housed systems. Access to feed via a specific feeding station may also reduce the number of competitive interactions that occur during feeding, compared to feeding from an open feed bunk like that used on commercial loose-housed farms.

Radio frequency has been employed for many years as a means of electronically identifying cows (Erasmus and Jansen, 1999). Recently, a radio frequency electronic monitoring

⁶A version of this appendix has been published. DeVries, T. J., M. A. G. von Keyserlingk, D. M. Weary, and K. A. Beauchemin. 2003. Validation of a system for monitoring feeding behavior of dairy cows. *J. Dairy Sci.* 86:3571-3574.

system (GrowSafe Systems Ltd., Airdrie, AB) has been designed that allows for the passive monitoring of individual cow presence at the feed bunk. The system was originally described by Sowell et al. (1998) and validated by Schwartzkopf-Genswein et al. (1999) for the monitoring of feeding behavior of feedlot cattle, but this technology has not been validated for measuring feeding behavior of loose-housed dairy cattle fed via a feed bunk. The objective of this study was to validate the measures generated by the GrowSafe system, by comparing these estimates with measures from time-lapse video recordings.

Two groups of six lactating Holstein cows were monitored continuously for 24 h using the GrowSafe feed bunk monitoring system and time-lapse video. The cows were housed in adjacent pens in a free-stall barn located at The University of British Columbia Dairy Education and Research Centre (Agassiz, BC, Canada) and were managed according to the guidelines set by the Canadian Council on Animal Care (1993). Each animal had access to a sand-bedded free stall. Cows were fed a TMR (30% corn silage, 8% grass silage, 4% alfalfa hay, 5% 3rd cut grass hay, 16% steam-rolled corn, and 37% concentrate mash on a DM basis) from a feed bunk (0.6 m of space/cow) with access via a neck rail. Animals were fed daily at approximately 0600 and 1600 h and were milked at approximately 0600 and 1700 h daily.

The GrowSafe system was modified from that previously described (Schwartzkopf-Genswein et al., 1999) so that data transfer from the reader panel to the computer occurred via radio frequency. The antenna mats (each 7.2 m long and 0.75 m wide) used to detect transponders were laid on the floor of the feed bunk adjacent to the tombstone with feed delivered on top of the mats. All animals were fitted with a passive transponder, which was encased in a plastic ear tag (All Flex, Inc., Dallas, TX) and attached to the bottom of the neck collar. The system was designed to detect the transponder when within 50 cm of the antenna mat,

such as when a cow placed her head under the neck rail and over the feed. This system worked by scanning set locations along the mat each at 6-s intervals. Whenever a transponder was within range, the reader panel recorded presence (a 'hit') of the transponder including time and location on the mat. These data (transponder number and time stamp) were downloaded continuously via radio frequency to a computer housed approximately 100 m from the panel. The computer was equipped with GrowSafe feed bunk monitoring software version 6.38.

A video camera (Panasonic WV-BP330; Osaka, Japan) was positioned approximately 6 m above the feed bunk of each experimental pen. Output from the cameras was recorded with a time-lapse video recorder (Panasonic AG-6540) in 48-h mode and a digital video multiplexer (Panasonic WJ-FS216). The clocks on the video recorder and the computer collecting the GrowSafe data were synchronized at the outset of the experiment. Red lights (100 W) were hung 6 m above the feed bunk to facilitate video recording at night. Cows were individually identified with symbols on both sides of their body using hair dye. Cows were scored as present at the feed bunk when the neck collar passed over the tombstone and above the feeding surface.

Raw data were summarized for each cow and for each minute of the day ($n=1440$), recording cow presence (1) or absence (0) at the feed bunk as determined by both the GrowSafe system and video.

Meal-based estimates of feeding behavior rely on the use of a meal criterion, which is the minimum time interval between visits to consider the next feed bunk visit as being part of a new meal. A meal criterion of 27.7 min was used following DeVries et al. (2003). This criterion was used to calculate meal frequency (meals/d), by counting the number of intervals between visits to the feed bunk that exceeded the criterion and adding 1. Meal duration (min/meal) was calculated

as the time from the first visit until, but not including, an interval between visits that exceeded the criterion.

We regressed (SAS, 1985) measures of behavior generated by GrowSafe (dependent variables) onto those from video (independent variables), testing for slope and intercept effects. Comparisons between the video and GrowSafe animal presence data within cows were performed by Chi-square 2 x 2 contingency tables (presence and absence at each minute, as determined by GrowSafe and video). These data were also used to calculate predictability (likelihood that a cow detected by GrowSafe is actually present at the feed bunk), sensitivity (likelihood that a cow present at the feed bunk is detected present by GrowSafe), and specificity (likelihood that a cow that is absent from the feed bunk is detected as absent by GrowSafe) estimates according to Martin et al. (1987).

The GrowSafe monitoring system provided estimates of feeding behavior that were very similar to that observed from video. Meal durations ranged from 31.72 to 57.49 min/meal for the GrowSafe data and 33.42 to 58.37 min/meal for the video data. Meal frequency ranged from 5 to 10 meals/d for both the GrowSafe and video data. The line equations and coefficients of determination were calculated for meal duration ($y = 0.96x + 0.63$, $R^2 = 0.98$) and for meal frequency ($y = x$, $R^2 = 1$). In both cases the coefficients were significant ($P < 0.001$), but the intercept did not differ from zero and the slope did not differ from one ($P > 0.3$).

In the previous validation work with this system using beef feedlot cattle, researchers found that the GrowSafe data for meal frequency and meal duration were overestimated compared to that found from video analysis (Schwartzkopf-Genswein et al., 1999). However, these researchers used a short meal criterion (85 s) that had not been established objectively. The use of an objectively calculated meal criterion (Tolkamp et al., 2000; DeVries et al., 2003) likely

results in a more biologically relevant estimate of meal measures. In the current study we used an objectively defined meal criterion and found a very good agreement between the GrowSafe meal measures and those from video.

The monitoring system records presence of individual cows at the feed bunk. Recent work with the GrowSafe system in a free-stall dairy barn has shown that the most repeatable measures across time were based on the number of hits (measure of presence) at the feed bunk: a measure which does not rely on a meal criterion (DeVries et al., 2003). However, prior to the current study, there has been no published work to validate the GrowSafe system's ability to monitor animal presence at the feed bunk. Figure 1 illustrates the agreement of estimates of animal presence as collected by both GrowSafe and video. For all 12 cows there was a high correlation (Table 1) between the two methods in detecting presence at the feed bunk. High values for predictability (96.5%), sensitivity (87.4%), and specificity (99.2%) all indicate that the GrowSafe system is a reasonable method for detecting cow presence.

For 12.6% of the observations that animals were confirmed present at the feed bunk using video, the GrowSafe system failed to record animal presence. These observations were likely due to several sources of error. External sources of radio frequency can cause lost signals from the system (Schwartzkopf-Genswein et al., 1999), and a local police station (0.5 km from the farm) was a likely source of such interference. There may also have been instances where the cow lifted her head out of the 50-cm read range but still remained over the tombstone. Reductions in the read range could have occurred due to changes in the orientation of the neck collar that place the transponder further from the mat. Indeed, such shifts would also change the orientation of the transponder to the mat, further reducing the read range (Schwartzkopf-Genswein et al., 1999).

Additionally, for 3.5% of observations when the GrowSafe systems indicated that a cow was present at the feed bunk, the video showed that the cow was not present. These extraneous observations were likely due to interference caused by the physical structures of the facility. For example, there were several physical structures (e.g. gates, fencing, lying stall partitions, and components of the feed bunk neck rail) that may have acted as unintended antennae for signals (Schwartzkopf-Genswein et al., 1999). As illustrated in Figure 1, even for the cow with the worst correlation (Cow 9) between the two data collection methods, all feeding observations by GrowSafe occurred during feeding bouts confirmed by video. This result suggests that it was likely the metal near the feed bunk (i.e. neck rail) that acted as a false antenna when cows were in close proximity to the feed bunk.

Although we have validated the GrowSafe records against the time-lapse video observations, some errors may also occur with video observations. For example, when using time-lapse video, errors may occur in recording the exact times when a cow's neck collar came within the read range of the mat. Additionally, due to the 6 s scanning method of the GrowSafe system, some animals may not be detected immediately when they start to feed, resulting in a different entry time compared to the video data.

In conclusion, the GrowSafe system can be used to monitor the feeding behavior of loose-housed dairy cattle. The GrowSafe system, used with an appropriate meal criterion, provides an accurate estimation of meal-based measures of feeding behavior. Furthermore, this system provides a reasonable estimate of when animals are present at the feed bunk. Recording errors can be reduced by carefully monitoring factors such as transponder position and the number of metallic objects within close proximity of the feeding area.

ACKNOWLEDGEMENTS

We thank the staff and students at The University of British Columbia's Dairy Education and Research Centre and the University's Animal Welfare Program. Trevor DeVries was supported by a Natural Sciences and Engineering Research Council of Canada Postgraduate Scholarship. The project was funded by the Natural Sciences and Engineering Research Council of Canada, through the Industrial Research Chair in Animal Welfare, and by contributions from the Dairy Farmers of Canada and many other donors listed at <http://www.landfood.ubc.ca/animalwelfare>.

Table 1. Records of cow presence (1) and absence (0) at the feed bunk for every minute of the day (n=1440) for 12 cows as recorded by the GrowSafe system and by video recordings, and the Phi correlation coefficients for chi-square test of association of the two methods. All Phi coefficients are significant at $P < 0.001$.

Cow	1, 1 ¹	1, 0 ²	0, 1 ³	0, 0 ⁴	Phi
1	320	6	29	1085	0.93
2	261	10	22	1147	0.93
3	235	17	39	1149	0.87
4	289	7	34	1110	0.92
5	253	9	38	1140	0.90
6	261	13	28	1138	0.91
7	287	3	17	1133	0.96
8	134	2	29	1275	0.89
9	247	18	74	1101	0.81
10	304	12	63	1061	0.86
11	248	5	53	1143	0.88
12	264	10	20	1164	0.93
Mean	258.6	9.3	37.2	1137.2	-

¹Number of minutes whereby both GrowSafe and video detected animal presence.

²Number of minutes whereby only GrowSafe detected animal presence.

³Number of minutes whereby only video detected animal presence.

⁴Number of minutes whereby neither GrowSafe nor video detected animal presence.

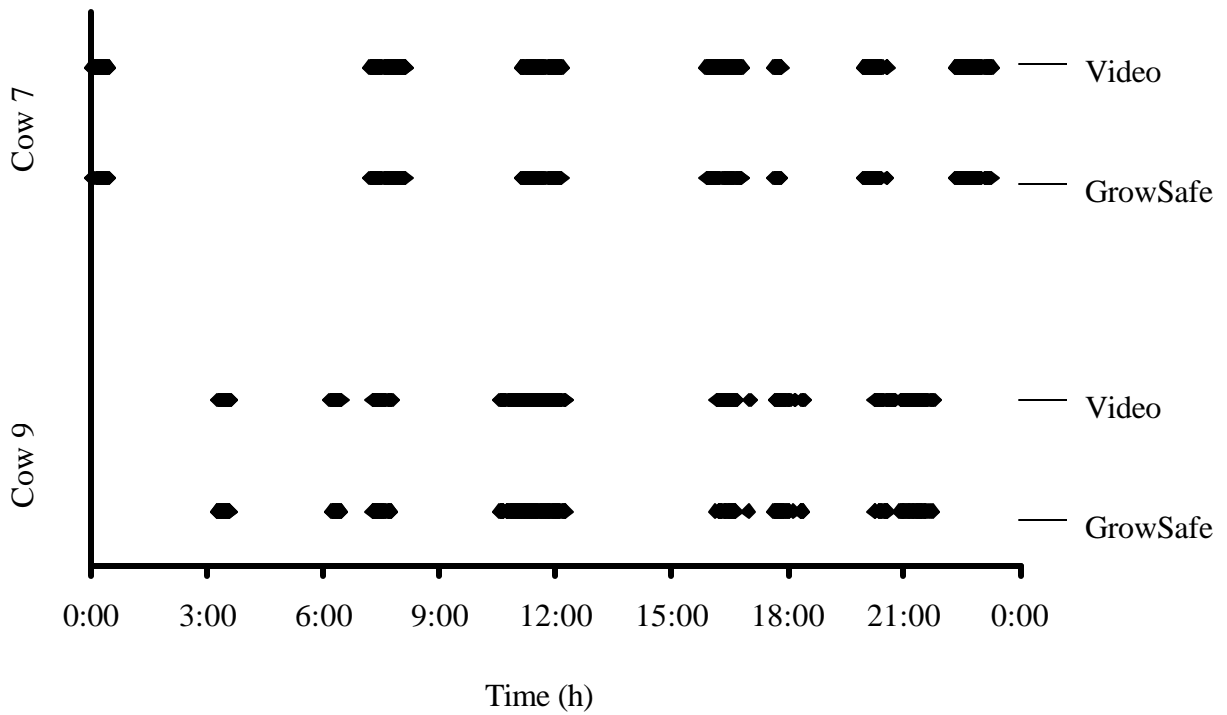

Figure 1. Feed bunk presence data (darkened lines) for 24 h, for two cows, collected using time-lapse video surveillance and the GrowSafe system. The two cows illustrate the best (Cow 7) and worst (Cow 9) correlations for the comparison between the two collection methods.

REFERENCES

- Canadian Council on Animal Care. 1993. Guide to the care and use of experimental animals. Vol. 1. E. D. Olfert, B. M. Cross, and A. A. McWilliam, ed. CCAC, Ottawa, ON, Canada.
- DeVries, T. J., M. A. G. von Keyserlingk, D. M. Weary, and K. A. Beauchemin. 2003. Measuring the feeding behavior of lactating dairy cows in early to peak lactation. *J. Dairy Sci.* 86:3354-3361.
- Eradus, W. J., and M. B. Jansen. 1999. Animal identification and monitoring. *Computers Electronics Agric.* 24:91-98.
- Friend, T. H., C. E. Polan, and M. L. McGilliard. 1977. Free stall and feed bunk requirements relative to behavior, production and individual feed intake in dairy cows. *J. Dairy Sci.* 60:108-116.
- Grant, R. J., and J. L. Albright. 2000. Feeding Behaviour. Pages 365-382 *in* Farm Animal Metabolism and Nutrition. J. P. F. D'Mello, ed. CABI Publishing, Wallingford, Oxon, UK.
- Martin, S. W., A. H. Meek, and P. Willeberg. 1987. *Veterinary Epidemiology - Principles and Methods.* Iowa State University Press, Ames.
- SAS User's Guide: Statistics, Version 5 Edition. 1985. SAS Inst., Inc., Cary, NC.
- Schwartzkopf-Genswein, K. S., C. Huisma. and T. A. McAllister. 1999. Validation of a radio frequency identification system for monitoring the feeding patters of feedlot cattle. *Livestock Prod. Sci.* 60:27-31.
- Sowell, B. F., J. P. G. Bowman, M. E. Branine, and M. E. Hubbert. 1998. Radio frequency technology to measure feeding behavior and health of feedlot steers. *Appl. Anim. Behav. Sci.* 59:277-284.
- Tolkamp, B. J., D. P. N. Schweitzer, and I. Kyriazakis. 2000. The biologically relevant unit for the analysis of short-term feeding behavior of dairy cows. *J. Dairy Sci.* 83:2057-2068.
- Vasilatos, R., and P. J. Wangsness. 1980. Feeding behavior of lactating dairy cows as measured by time-lapse photography. *J. Dairy Sci.* 63:412-416.